

Vitaliy Korendiy¹, Andy Augousti²,
Olena Lanets³, Taras Vilchynskiy⁴, Vladyslav Kyrychuk⁵, Oleksandr Yaniv⁶, Roman Protasov⁷

¹ Department of Technical Mechanics and Engineering Graphics, Lviv Polytechnic National University, Ukraine, Lviv, S. Bandery street 12, E-mail: vitalii.m.korendii@lpnu.ua, ORCID 0000-0002-6025-3013

² Department of Mechanical Engineering, Kingston University, Kingston Upon Thames, KT1 1LQ, London, United Kingdom, E-mail: augousti@kingston.ac.uk, ORCID 0000-0003-3000-9332

³ Department of Mechanical Engineering, Kingston University, Kingston Upon Thames, KT1 1LQ, London, United Kingdom, E-mail: o.lanets@kingston.ac.uk, ORCID 0000-0001-7149-0957

⁴ Department of Technical Mechanics and Engineering Graphics, Lviv Polytechnic National University, Ukraine, Lviv, S. Bandery street 12, E-mail: taras.r.vilchynskiy@lpnu.ua

⁵ Department of Technical Mechanics and Engineering Graphics, Lviv Polytechnic National University, Ukraine, Lviv, S. Bandery street 12, E-mail: vladyslav.v.kyrychuk@lpnu.ua

⁶ Department of Technical Mechanics and Engineering Graphics, Lviv Polytechnic National University, Ukraine, Lviv, S. Bandery street 12, E-mail: oleksandr.m.yaniv@lpnu.ua, ORCID 0009-0001-2491-5278

⁷ Faculty of Mechanical Engineering, Slovak University of Technology in Bratislava, Slovak Republic, Bratislava, Nam. Slobody 17, E-mail: roman.protasov@stuba.sk, ORCID 0000-0003-1611-0610

NOVEL CONCEPTS AND DESIGNS OF INERTIAL VIBRATION EXCITERS FOR INDUSTRIAL VIBRATORY EQUIPMENT: A REVIEW

Received: August 22, 2024 / Revised: September 28, 2024 / Accepted: December 6, 2024

© Korendiy V., Augousti A., Lanets O., Vilchynskiy T., Kyrychuk V., Yaniv O., Protasov R., 2024

Abstract. The operational efficiency and adaptability of industrial vibratory equipment are strongly influenced by the design and performance of vibration exciters. Vibratory equipment with such mechanisms is widely used in industries such as mining, construction, food processing, pharmaceuticals, and agriculture, where efficient material handling and precise motion control are critical. Traditional systems face several challenges, including energy inefficiency, limited trajectory control, and a lack of flexibility for diverse industrial applications. This study aims to overcome these limitations by proposing innovative designs for vibratory exciters, focusing on symmetric planetary-type mechanisms, self-regulating vibration exciters with adjustable inertial parameters, and twin crank-slider mechanisms.

The research employs a comprehensive methodology that integrates mathematical modeling using Euler-Lagrange equations, simulation-based analysis in Mathematica and SolidWorks, and validation under varying operational conditions. Results indicate that the symmetric planetary-type mechanism can generate complex motion trajectories, including triangular, elliptical, and hexagonal paths, enabling superior adaptability. Similarly, the twin crank-slider mechanism provides precise multi-mode control over trajectory configurations, achieving linear, circular, and elliptical oscillations essential for tailored operational performance. The self-regulating planetary vibration exciter enhances operational efficiency by allowing real-time adjustments of inertial parameters, ensuring compatibility with specific technological requirements such as sieving, conveying, and compacting processes.

The originality of this work lies in its ability to address the core issues of energy optimization, adaptability, and advanced trajectory control. By introducing these novel solutions, the study significantly enhances the practical value of vibratory systems in industrial processes. Future research will focus on experimental validation of the proposed mechanisms and further optimization

of their parameters. Additionally, expanding these designs' applicability to large-scale industrial machinery will ensure broader implementation and increased efficiency across diverse engineering domains.

Keywords: vibration exciters, planetary mechanisms, crank-slider mechanisms, trajectory control, energy efficiency, industrial applications.

Introduction

Industrial vibratory equipment is widely used for transporting, sieving, and compacting bulk materials, which makes it indispensable in various industries. The main element of such equipment is vibration exciters, which determine the vibratory equipment's vibration characteristics and overall efficiency. Despite the great variety of existing vibration exciters, achieving high accuracy and energy efficiency requires further improvement of these devices.

This article is devoted to studying modern ideas for improving vibration exciters, particularly such designs as planetary and crank-type vibration exciters. The purpose of the work is to study the possibilities of improving energy efficiency and meeting the technological requirements of modern vibration systems.

Problem Statement

Despite the wide application of vibration-driven equipment, existing vibration exciters face several critical challenges. These include insufficient energy efficiency, limited adaptability to varying operational conditions, and constraints in precision control of vibration characteristics. Additionally, the need to reduce wear and tear on mechanical components while maintaining high-performance levels places further demands on the design and functionality of vibration exciters.

Current advancements in planetary mechanisms, hydraulic systems, and self-tuning technologies offer promising solutions. However, their integration into industrial applications requires a thorough investigation of their performance, cost-effectiveness, and compatibility with existing systems. Addressing these challenges is essential to meet the growing technological demands of modern industries and to ensure the sustainable development of vibratory equipment, as well, it requires innovative approaches to the design and operation of vibration exciters, incorporating energy-efficient mechanisms, adaptable trajectories, and stable dynamic behaviour.

Review of Vibratory Exciters

In inertial centrifugal vibration exciters, the excitation force is generated by rotating one or more unbalanced masses. These exciters belong to the earliest designs and are currently represented in a wide variety of types [1].

The excitation force of a vibration exciter can be either rotary (rotating around an axis perpendicular to the force) or directional. Vibratory exciters with rotary excitation forces are known as unbalanced exciters. The most common type of unbalanced exciter is shown in Fig. 1a. It consists of an unbalanced mass (1) mounted on a shaft (2) that rotates with angular velocity ω in bearings of the housing (3), which is attached to the vibratory machine. During the rotation of the unbalanced mass, a centrifugal excitation force F_m is generated, which sets the entire oscillatory system in motion along a circular (or elliptical) trajectory, as determined by Eq. (1)

	(1)
--	-----

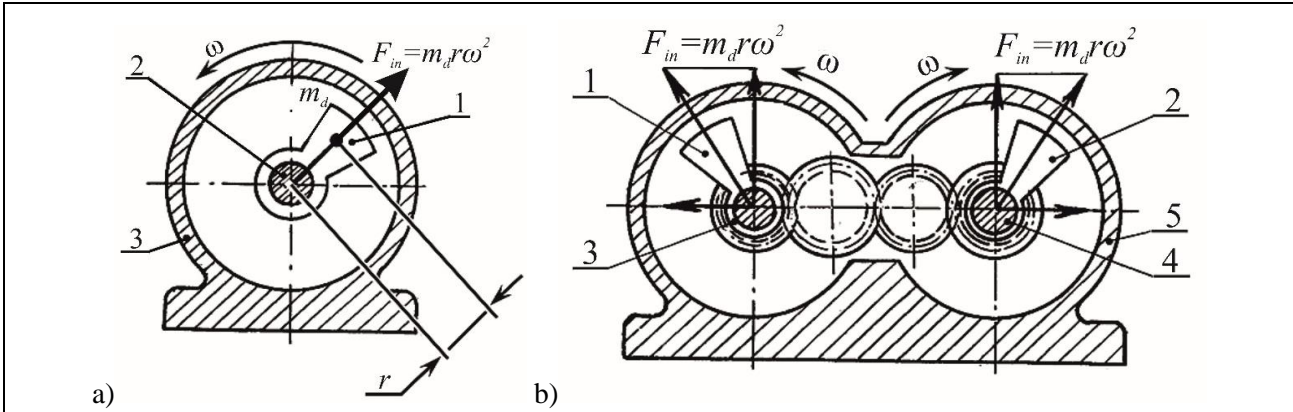

Fig. 1. a) Unbalanced vibration exciter b) Self-balancing vibration exciter [1]

Directional excitation forces are achieved in self-balancing vibration exciters (Fig. 1b). When two unbalanced masses rotating synchronously are mounted on the working element, a directed alternating excitation force is generated, resulting in the oscillatory system moving along a linear trajectory (directed oscillations). This type of vibration exciter (Fig. 1 b) consists of two unbalanced exciters with masses (1 and 2) mounted on shafts (3 and 4), which are kinetically linked by a pair of gears and enclosed in a single housing (5). The unbalanced masses rotate in opposite directions with equal angular velocity so that they simultaneously occupy horizontal and vertical positions. As a result, the horizontal components of the centrifugal forces cancel each other at any given moment, while the vertical components are summed. The resulting excitation force will equal $2F_{in}$.

However, this synchronization construction has disadvantages. Gear wheels experience significant dynamic loads, which are a frequent cause of failures. A more rational approach, if it can be structurally implemented, is to use the synchronization theory of prof. Yaroshevych M.P. [2]. In this case, the two unbalanced masses will independently achieve a stable out-of-phase motion.

The oscillation excitation scheme (Fig. 1a) is primarily used in the design of vibratory finishing machines, mixers, etc., while the construction shown in Fig. 1b is used for driving conveyors, feeders, and screens.

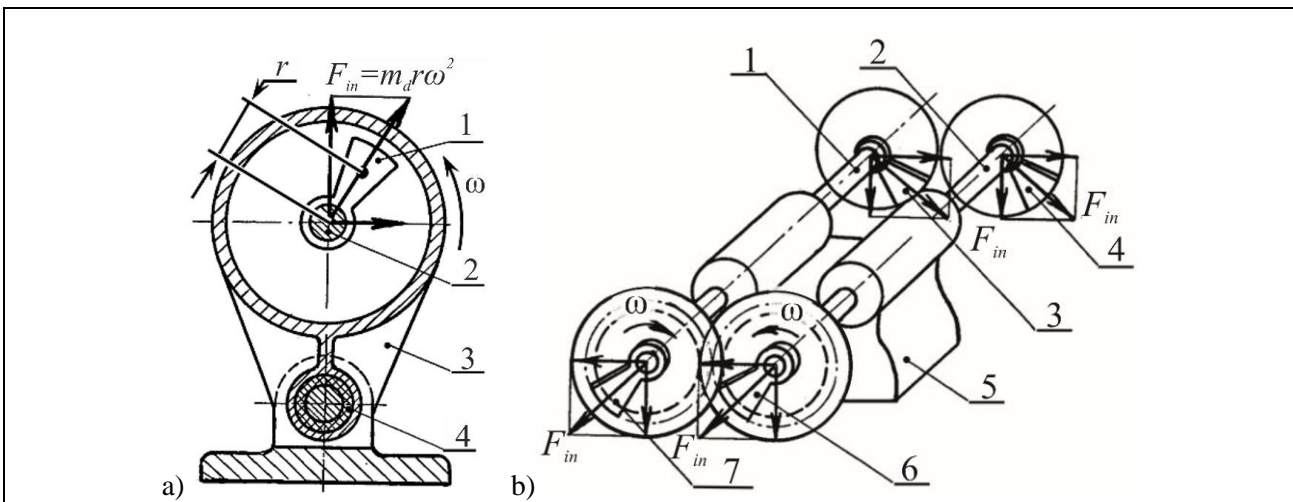

Fig. 2. a) Pendulum vibratory exciter b) Four-mass vibratory exciter [1]

It is also possible to achieve a directed excitation force with a single unbalanced exciter. This type of exciter is called a pendulum exciter (Fig. 2a). It is mounted to the vibratory machine through an elastic rubber hinge (4). A rotating shaft (2) is installed inside the exciter housing (3), and the unbalanced mass (1) is fixed on the shaft. The horizontal component of the centrifugal force creates a moment relative to the

suspension axis, which, due to the low torsional stiffness of the elastic hinge, almost doesn't transmit vibrations to the machine. The vertical component constantly passes through the axis of the elastic hinge and fully transmits vibrations to the machine. Fig. 2b shows a four-mass vibratory exciter designed to generate helical oscillations. This vibratory exciter consists of shafts (1 and 2) connected by gears, on which the unbalanced masses (3, 4, 6, and 7) are mounted. The unbalanced masses on each shaft are displaced relative to each other by a certain angle and rotate in opposite directions within the housing (5). The sum of the vertical components of the centrifugal forces together generates a vertical driving force, while the horizontal components generate a torque.

The exciters discussed above have a direct connection to the motor, forming a single electromechanical system. This creates challenges for their direct use in resonant systems without protective measures to safeguard the motor.

Inertial unbalanced vibration exciters also include those in which the rotation of the unbalanced mass is driven by compressed air flow. Pneumatic ball vibration exciters are used to achieve high frequencies in the range of 120 ... 800 Hz (Fig. 3a). These vibratory exciters consist of a housing (1) with a closed circular groove (2) that freely accommodates a steel ball (3). The body of the vibration exciter has a fitting 4 with a nozzle 5, intended for connecting a hose that supplies compressed air. In the central part of the end walls of the body, there are holes 6 for the exhaust of compressed air into the atmosphere. The vibration exciter operates as follows: compressed air passing through the nozzle causes the ball 3 to move along the annular groove. A centrifugal excitation force is generated because of the circular movement of the ball. This force induces the oscillatory motion of the system. The frequency of oscillations is regulated by a throttle in the pneumatic network. [1]

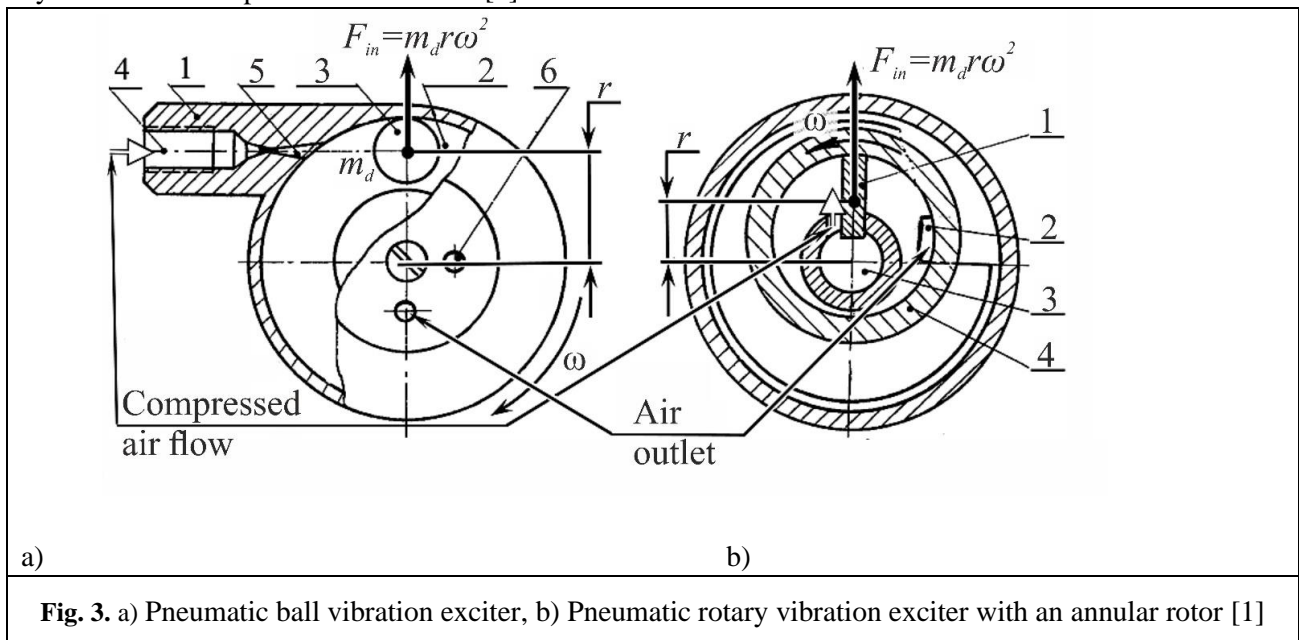

Fig. 3. a) Pneumatic ball vibration exciter, b) Pneumatic rotary vibration exciter with an annular rotor [1]

Another type of pneumatic vibration exciter (Fig. 3a) generates oscillations by rotating an unbalanced annular rotor (4), which is continuously pressed against a plate (1). Compressed air enters the exciter through an intake port (3) in the housing. Under the action of the air, the rotor shifts to the left and rotates in the direction shown by the arrow until the exhaust port (2) is opened. Before the exhaust port opens, the rotating rotor depresses the plate (1), closing the intake port. When the exhaust port opens, the rotor creates a new cavity next to the moving plate, and the process repeats. The frequency of such a vibration exciter can reach 80... 300 Hz. Designs with housing diameters of 100 mm can produce excitation forces up to 20000 H.

To enhance the control of vibration trajectories and increase precision, recent advancements have

Novel Concepts and Designs of Inertial Vibration Exciters for Industrial Vibratory Equipment: A Review

emphasized planetary vibration exciters. These mechanisms enable various trajectory shapes, such as circular, elliptical, and rectilinear. By allowing greater flexibility in application, planetary exciters broaden the usability of vibration systems across diverse industrial processes. The operational efficiency of vibratory technological equipment can be significantly enhanced by employing planetary-type inertial vibration exciters. Research by Palevičius and Ragulskis highlights the self-resonance effect of such systems, demonstrating their potential for improving performance through controlled vibration parameters [3]. The new principle of periodic force generation using rotational-to-inertial force conversion was proposed in work [4], achieving high energy efficiency and eliminating recoil forces typical of traditional vibration exciters. Further advancements in planetary-type exciters, such as vibrators with adjustable parameters and chain gears, have been explored to address specific industrial challenges, including bulk material handling and construction equipment [5].

Innovative designs, such as asymmetric self-regulating planetary vibration exciters, have also been studied for their ability to adjust inertial parameters dynamically, ensuring optimal performance under changing conditions [6]. These designs show promise for snowplows, construction machinery, and other applications requiring high adaptability and efficiency [7]. Double crank-slider mechanisms have also emerged as a powerful alternative, offering enhanced vibration stability and synchronization. Their design ensures uniform load distribution and minimizes parasitic vibrations, effectively adapting the equipment to fluctuating operating.

The use of crank-type vibration exciters in vibratory conveyors and screens has been widely explored. In [8] it is proposed a crank-type device capable of generating excitation forces with controllable magnitude and direction, highlighting its potential for diverse industrial uses. The dynamic behavior of vibratory systems has been extensively studied through mathematical models to evaluate the influence of design parameters and external excitations. Their validation under various operational conditions highlights the importance of precise parameter selection. [9]. Recent advancements in motion generation techniques for linkage mechanisms have significantly enhanced the efficiency and versatility of vibratory systems. A novel method to address the motion generation problem in spherical four-bar crank-slider mechanisms is proposed in [10]. This approach establishes an output properties database and provides a dimension parameter solution, enabling the generation of infinite prescribed positions with precision and simplicity. Moreover, its adaptability extends to various linkage mechanisms for motion control applications.

Objectives and Problems of Research

The primary objective of this research is to explore innovative ideas for improving the design and operation of vibration exciters. As critical components of vibration-driven equipment, these devices directly influence operational precision, energy efficiency, and adaptability. Integrating these aspects offers a comprehensive pathway to advancing modern vibration technologies. The identified problems that require further development aimed at increasing the efficiency of vibration equipment are considered in our research. Development and application of new ideas for design will allow the achievement of set objectives and as a result, enhance the control of vibration trajectories and increase precision, to generate sufficient excitation force at low frequencies while offering stability and performance under high loads, uniform load distribution, and minimizing parasitic vibrations, to mitigate the effects of unwanted vibrations on supporting structures.

Various approaches are suggested for achieving these improvements, laying the foundation for advancements in vibratory equipment and its industrial applications.

Main Material Presentation

This section presents a comprehensive set of ideas for improving vibration exciters, directly addressing the objectives and challenges outlined in the previous section. The proposed advancements

focus on enhancing critical areas identified as requiring improvement, including energy efficiency, trajectory control, stability, and operational reliability.

To provide the control of the motion trajectories of an unbalanced mass in an inertial vibration exciter the use of a single-degree-of-freedom planetary mechanism is presented [11]. Single-mass vibration machines with symmetric planetary-type vibration exciter suggested to provide triangular, rectangular, hexagonal, and other vibration trajectories of a single-mass vibration system, which can oscillate in two mutually perpendicular directions. Inertial forces are generated by the planet gear, when it rolls on the outside of the sun gear pitch circle, or on the inside of the ring gear pitch circle. (Fig.4)

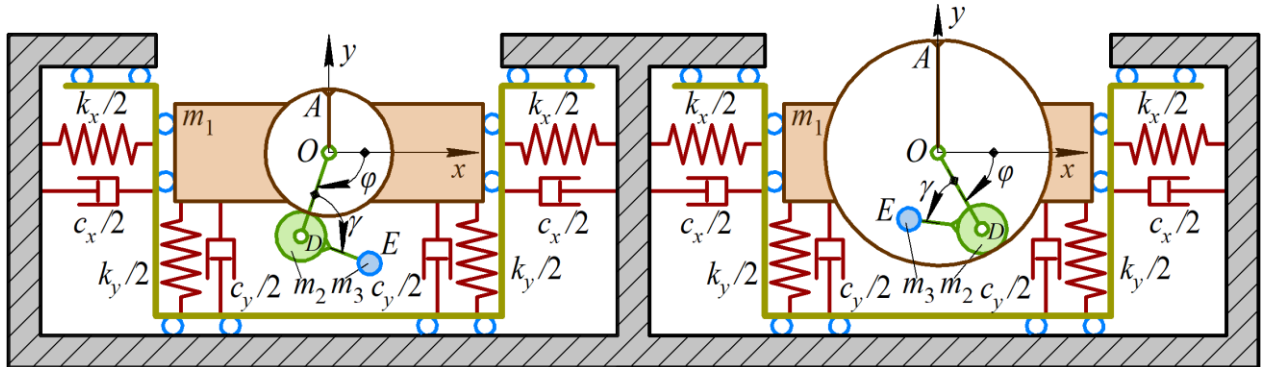

Fig. 4. Schematic representation of a single-mass vibratory system with planetary-type exciters [11]

Depending on the design the corresponding sun gear (or ring gear) is fixed to the oscillating body. The motor shaft is positioned at hinge O , enabling the clockwise rotation of the carrier OD . The rotation of the planet gear and the disturbing mass around hinge D depends on whether the exciter uses a fixed sun gear or a fixed ring gear. These rotational directions are illustrated in Fig. 4 and are defined by the angle γ . The oscillating body undergoes periodic planar motion, constrained by a set of horizontal and vertical spring-damper elements. These elements are characterized by stiffness and damping coefficients.

The research conducted using Mathematica and SolidWorks software validates the adequacy of the proposed symmetric planetary-type vibration exciter. The mathematical model of the system, developed using Euler-Lagrange equations, provided a robust framework for analysing motion dynamics. Simulations with the 3D model of the vibratory system in SolidWorks allowed for a detailed examination of motion trajectories and kinematic characteristics under specific parameters.

The studies revealed the significant impact of inertial and geometric parameters on the generated trajectories and system behavior. In particular, the case of steady oscillations with a symmetric planetary-type vibration exciter, where the sun gear ($k=1$) is fixed, demonstrated the system's capability to achieve predictable and stable motion. Numerical modeling results (Fig. 5) include time-dependent horizontal and vertical displacements, velocities, and accelerations, providing comprehensive evidence of the exciter's performance and the influence of design parameters on its operation.

The research of single-mass vibration machines with symmetric planetary-type vibration exciter to provide triangular, rectangular, hexagonal, and other vibration trajectories of a single-mass vibration system was carried out in the work [11] using the Mathematica software. For this purpose, a mathematical model of the system motion was used, developed using the Euler-Lagrange equations. SolidWorks software using a 3D model of the vibration system was used for simulation of the system motion (Fig.6).

The studies showed the influence of the inertial and geometric parameters included in the model on the trajectory and considered the kinematic characteristics of the body with the specified parameters.

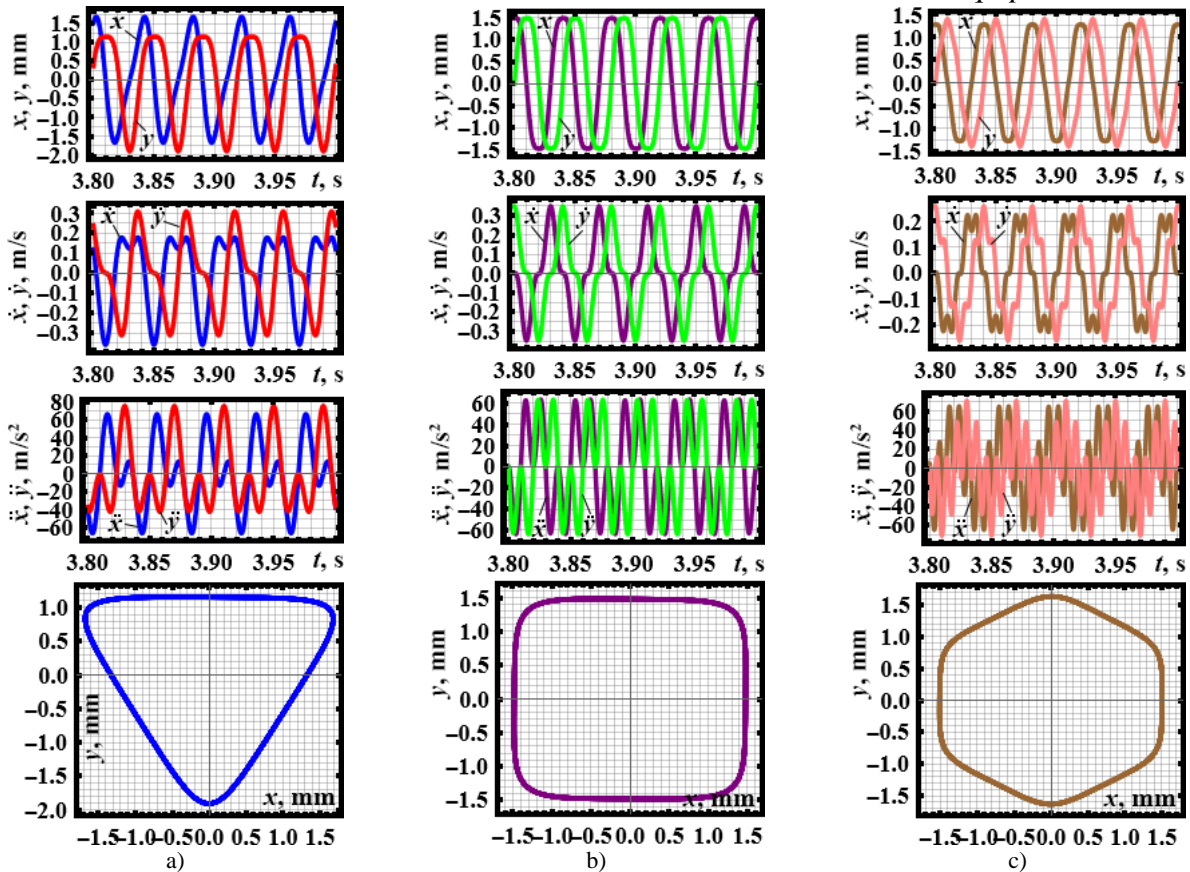

Fig. 5. Motion analysis of the system with varying planetary-type exciter design parameters [11]

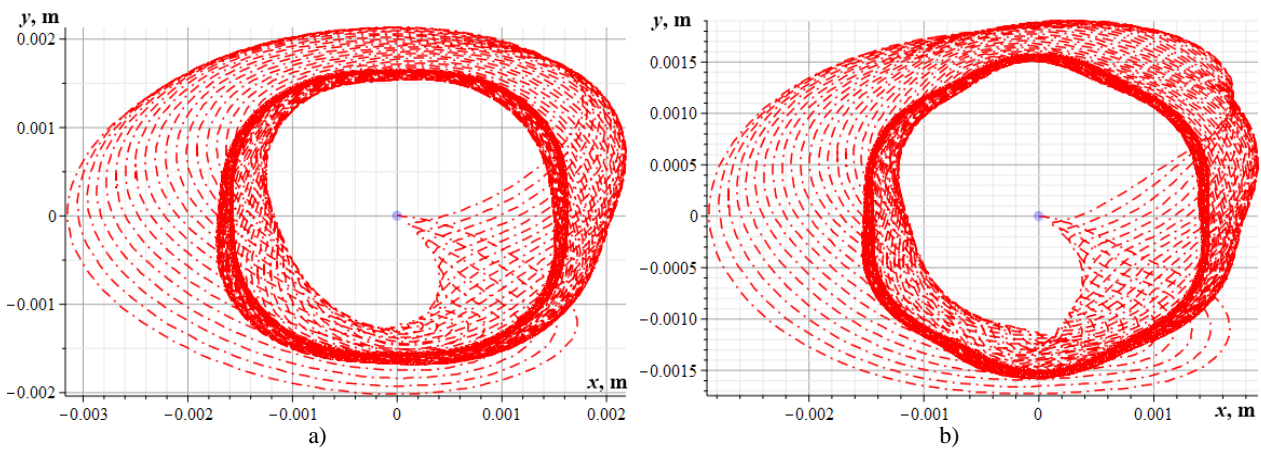

Fig. 6. Trajectories of the unbalanced mass motion for different geometric parameters of the planetary-type vibration exciter [11]

The results of the simulation performed in Mathematica software and the results obtained in SolidWorks software show the comparability of the results.

The main idea behind the implementation of the proposed improvement is the use of a single-stage planetary-type mechanism to form controlled trajectories of motion of the unbalanced mass of the inertial vibration exciter, which will allow control of the direction of the generated vibrations of the equipment. Namely, the generation of triangular, rectangular and similar multi-angle oscillations of a single-mass vibration system driven by a planetary-type exciter. The proposed design of the vibration exciter is presented in Fig. 7 [12].

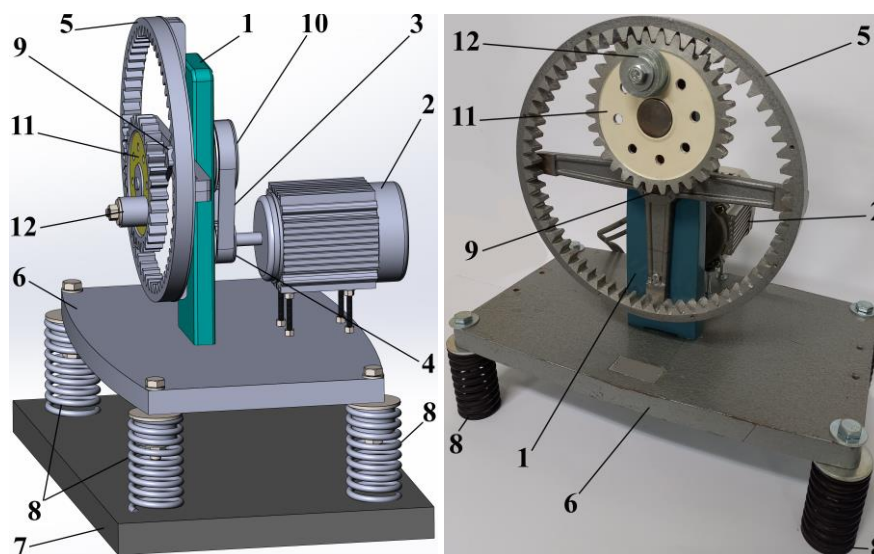
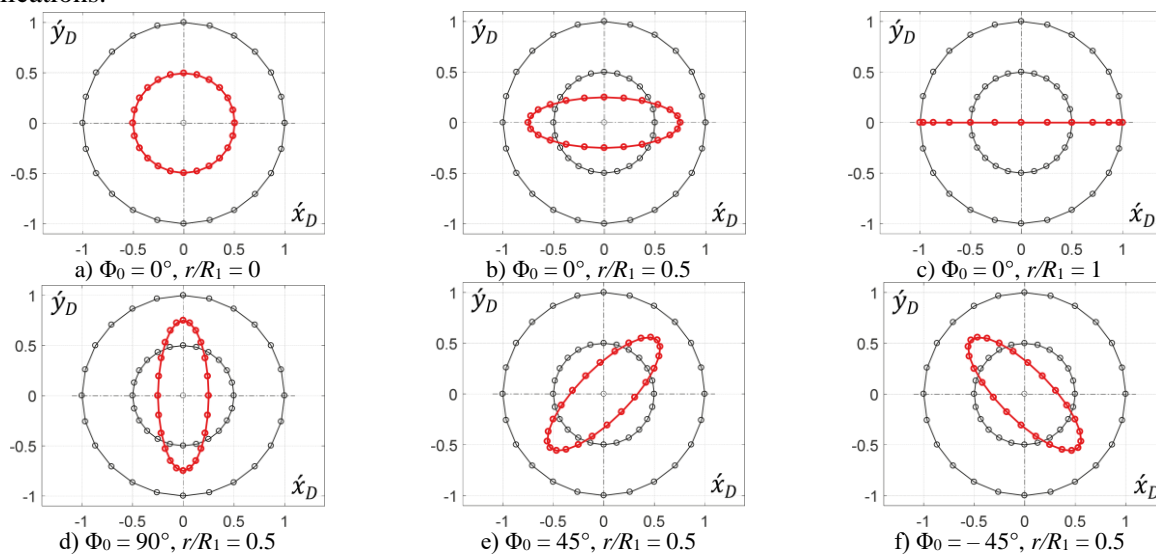

Fig. 7. Single-stage planetary-type vibratory exciter: structural components and assembly [12]: 1 - planetary-type mechanism, 2 - electric motor, 3 - toothed belt transmission, 4 - driving pulley, 5 - ring gear, 6 - machine's body, 7 - stationary support surface, 8 - set of four coil-type cylindrical springs, 9 - planet carrier, 10 - driven pulley shaft, 11 - planet gear, 12 - unbalanced mass [12]

Based on the analytical dependencies derived in [12], the trajectories of the unbalanced mass motion were constructed at different geometrical parameters of the planetary mechanism (see Fig. 8). The analysis of trajectories of the unbalanced mass under varying initial conditions and geometric ratios (Fig.8) reveals the diverse motion paths that can be generated, highlighting their practical applications in industrial vibratory equipment. This demonstrates the system's versatility in adapting to specific industrial needs by adjusting initial conditions and geometric ratios, ensuring optimized performance across different vibratory applications.



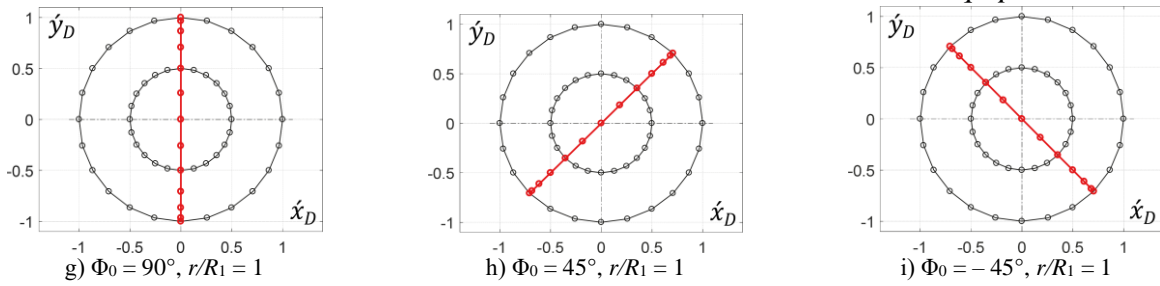

Fig. 8. Influence of initial conditions and geometric ratios on motion trajectories of the unbalanced mass [12]

The analysis of dependencies of analogues of the unbalanced mass speeds (Fig. 9) and accelerations (Fig 10) on the rotation angle of an unbalanced mass carried out in [12] proves the possibility of using the proposed drive design in vibration equipment.

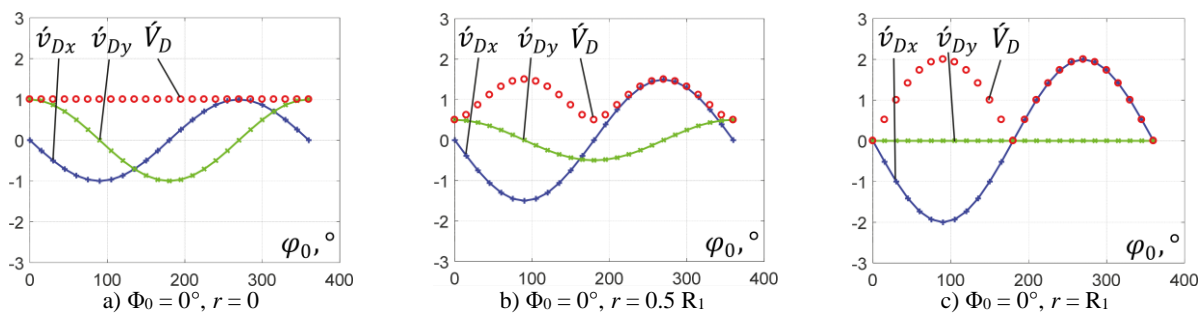

Fig. 9. Speed characteristics of the unbalanced mass [12]

From the graphs of speeds and accelerations (Figs. 9 and 10), it can be concluded that there is a change in the components of speeds and accelerations. Namely, the horizontal quantities take on larger peak values than the vertical ones. In rectilinear motion, the total velocities and accelerations are equal to the horizontal ones and periodically change, reaching maximum values. If compared with the values obtained in conditions of circular motion, they are twice as high. While the vertical components of velocities and accelerations are equal to zero.

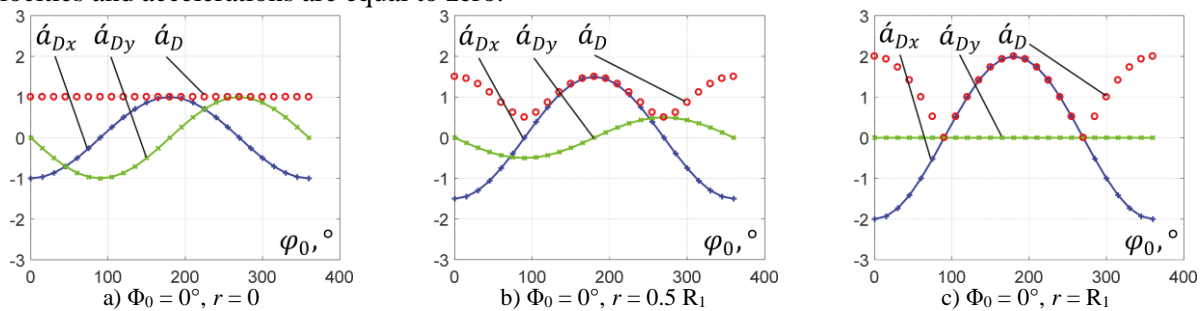

Fig. 10. Acceleration components of the unbalanced mass [12]

To enhance the efficiency, stability, and adaptability of vibratory equipment such as conveyors and screeners, it is proposed an improved design of a planetary-type vibration exciter with self-regulating inertial parameters [13]. Unlike conventional designs, this exciter autonomously adjusts its parameters to match technological requirements, ensuring high performance under varying operating conditions.

Improved design of an asymmetric planetary vibration exciter with the ability to self-regulate shown in Fig.11 [13]. Due to its design, it can change inertial characteristics depending on technological requirements, ensuring flexibility and efficiency in its performance. The exciter is connected to the oscillating platform via plate 1, to which the ring gear 2 is fixed. The driving motor 3 is mounted on plate 4, offset from the ring gear's geometric center. This configuration causes the carrier bar 6 to slide along the guide (linear) bearing 5 on the motor shaft, adjusting its position. The planet gear 8, supported by ball

bearings on axis 9, rolls along the inner pitch circle of the ring gear 2. A coil spring 7 ensures reliable contact between the planet gear and ring gear. Centrifugal weights are placed on the guide (linear) bearing 12, which slides along the guiding bar 13. The rubber damper 11 and coil spring 14, regulated by nut 15, control the position of the weights. This asymmetric planetary-type exciter generates centrifugal and Coriolis forces, as well as gyroscopic moments, enhancing the dynamic performance of the system. The self-regulating mechanism adjusts the inertial parameters of the centrifugal unit, significantly improving the efficiency of screening and conveying processes.

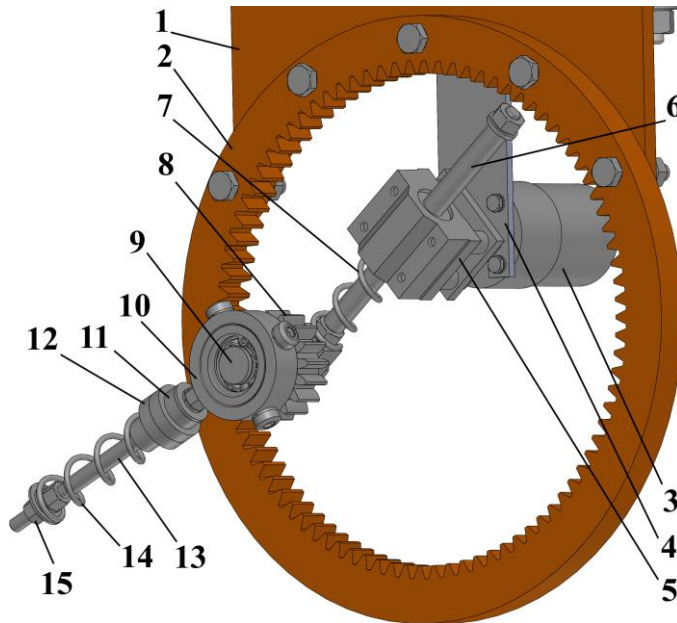

Fig. 11. Structural layout of a planetary-type vibration exciter [13]: 1 - plate, 2 - ring gear, 3 - driving motor, 4 - plate, 5 - guide (linear) bearing, 6 - carrier bar, 7 - coil spring, 8 - planet gear, 9 - axis, 10 - casing, 11 - rubber damper, 12 - guide (linear) bearing, 13 - guiding bar, 14 - coil spring, 15 - nut.[13]

The results of numerical simulation performed in Mathematica software using Runge-Kutta methods using a mathematical model developed based on the Lagrange-d'Alembert principle are shown in Fig. 12 [13]. Fig. 12 illustrates the force-time dependencies of the vibration exciter's oscillating bodies, highlighting the contributions of centrifugal and Coriolis forces to the system dynamics. The maximal excitation effect on the system vibrations is primarily exerted by the centrifugal forces.

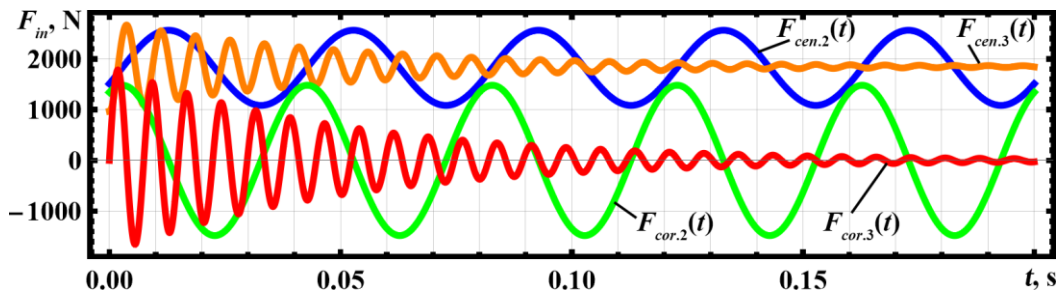

Fig. 12. Force-time dependencies of vibration exciter's oscillating bodies [13]

As can be seen from the diagrams shown in Fig. 13 [13], the oscillations of the unbalanced mass are quite intense at the beginning of the movement, but after the end of the transient modes, the oscillations are established in a certain range of deviations and stabilize. The working body of the vibrating equipment undergoes transient processes and the amplitude of the oscillations gradually increases, reaching stable operation after 1.5, ..., 2 s after start.

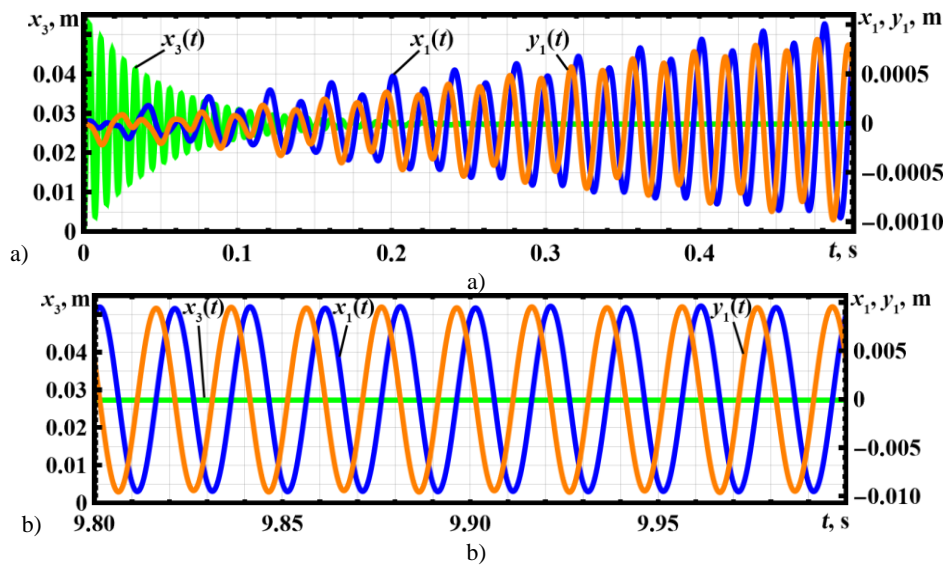

Fig. 13. Oscillatory motion of masses over time: a) initial phase $t = 0 \dots 0.5$ s; b) steady-state phase $t = 9.8 \dots 10$ s [13]

The study [13] showed that by changing the excitation frequency and the ratio of geometric parameters, it is possible to adapt the system to different operating modes.

The method proposed in [14] for determining the necessary moment of perturbation ensures the proper functioning of vibration equipment and improves efficiency. The dynamic diagram of the planetary-type mechanism presented in this study is identical to the one described in [11].

Analytical expressions, based on simplified dynamic diagrams of two different designs of planetary-type mechanisms, were derived in [14] to describe the force parameters of the considered mechanical systems. The Fig. 14a shows the trajectories generated for different initial conditions and geometric parameters. The motion paths include vertical, horizontal, and inclined rectilinear trajectories, influenced by the angular conditions. By adjusting the initial conditions, such as the carrier inclination angles, and geometric parameters, it is possible to control and achieve different types of motion trajectories for the unbalanced body. The time-dependence diagram for reaction force R_0 in the central hinge (Fig. 14b) is presented for various carrier angular speeds. As the angular velocity increases, the reaction force amplitude rises, with the maximum value reaching approximately 900 N at $\omega = 628 \text{ s}^{-1}$.

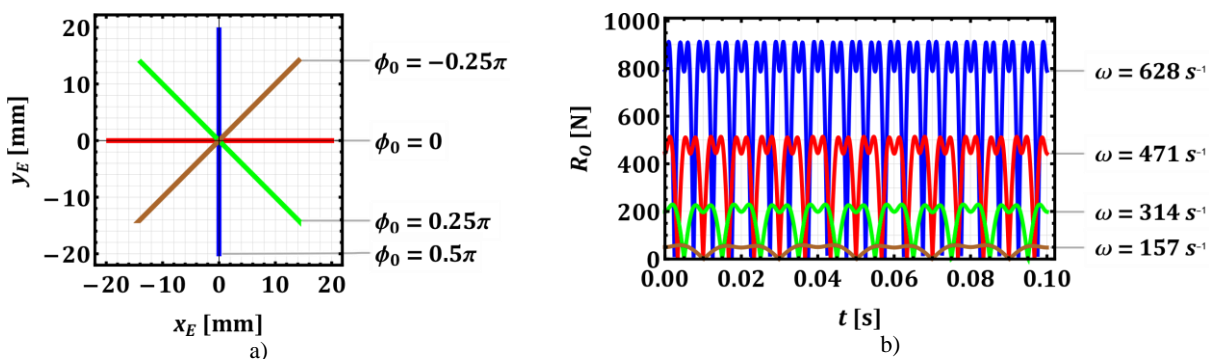

Fig. 14. Dependence of the imbalanced body trajectory a) and central hinge reactions b) on carrier inclination angles and carrier angular speeds

The graph (Fig. 15) illustrates the time-dependent changes in the inertial and gravitational moments acting on the carrier of the planetary-type mechanism under different operational angular speeds. The time-dependent variations in the inertial and gravitational moments acting on the carrier of the planetary-type mechanism are significantly influenced by the operational angular velocity. As the angular velocity increases, both the frequency and amplitude of the oscillations grow, demonstrating the dynamic sensitivity of the system to changes in rotational speed. This behavior underscores the need for precise control of the angular velocity to optimize the system's performance, especially in applications requiring stable and predictable vibrational forces.

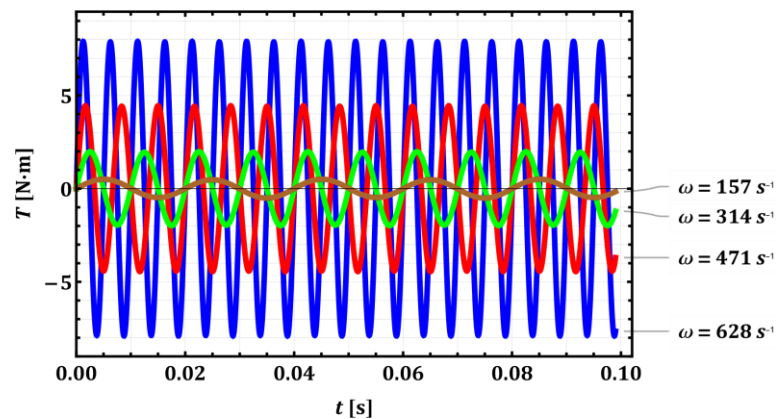

Fig. 15. Time changes of inertial and gravitational forces' moments on the carrier of the planetary-type mechanism under different operating conditions

The type of vibration exciter is essential in determining the performance and reliability of vibratory equipment. Vibratory systems are often presented with centrifugal vibration exciters such as unbalanced rotors and eccentric shafts. Unlike inertially driven systems, a significant portion of vibratory equipment incorporates crank-type exciters, offering distinct operational advantages.

A slider-crank mechanism as an integral part of inertial vibration exciters demonstrated its potential. This mechanism offers precise control over vibration parameters, including trajectory, frequency, and amplitude, enabling tailored vibrations to meet specific industrial needs. Building on the advancements in vibratory equipment design, the study [15] emphasizes the critical role of geometric synthesis in developing efficient vibration exciters. The research establishes a methodology for defining the geometric parameters of a slider-crank mechanism to achieve precise trajectory control. The study demonstrates the mechanism's ability to generate specific paths, including circular, elliptical, and linear trajectories, by adjusting parameters such as link lengths and angular configurations. These trajectories are vital for enhancing the adaptability and performance of vibratory equipment in industrial applications.

Synthesis of geometric parameters for such a mechanism showed possibility to achieve specific motion trajectories for an unbalanced mass, such as circular, elliptical and linear trajectories [15]. This gives the possibility to adjust it according to technological requirements.

Simulations in Mathematica and SolidWorks validated the feasibility and practicality of the proposed mechanism, as illustrated in Fig. 16 [15].

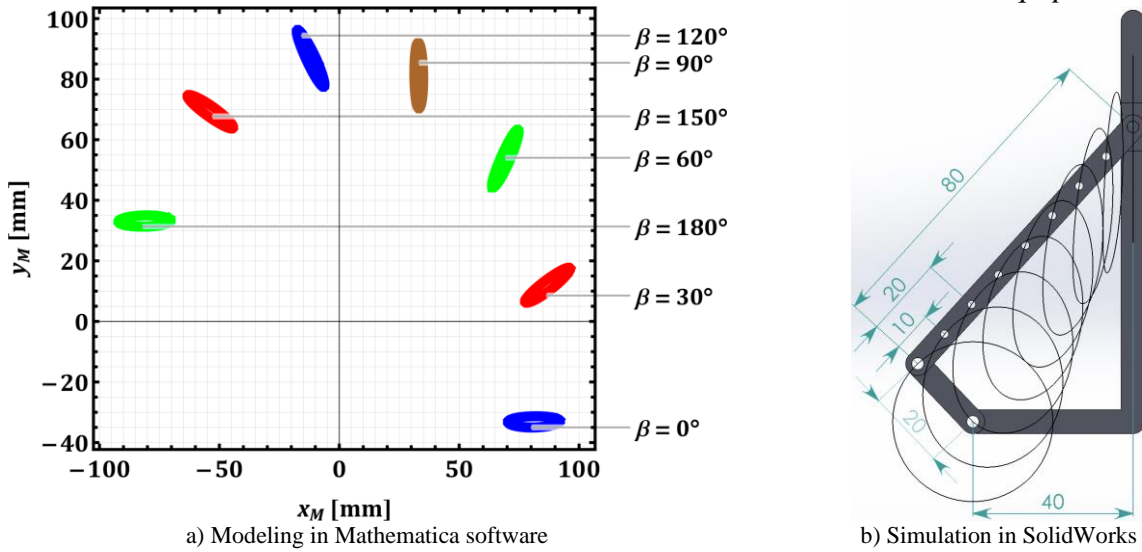

Fig. 16. Motion trajectories of the connecting rod point under different angles β and link dimensions l_2 and l_3 [15]

The proposed slider-crank mechanism significantly enhances the operational flexibility of vibratory systems. By enabling precise control over vibration trajectories, it addresses critical challenges in modern vibratory equipment design. This adaptability makes the mechanism ideal for applications requiring customized vibration parameters, such as material handling, sieving, and compacting.

The dynamic analysis of the vibratory system driven by a twin crank-slider excitation mechanism proved its potential in vibratory equipment [16]. It emphasizes the ability of the mechanism to provide controllable oscillation parameters suitable for varying industrial needs. This includes the potential to generate rectilinear, elliptical, and circular oscillations of the working member, which can be tailored to meet the specific requirements for sieving, conveying, or compacting materials. The system in Fig. 17 incorporates a twin crank-slider mechanism, which allows for precise control over vibration trajectories.

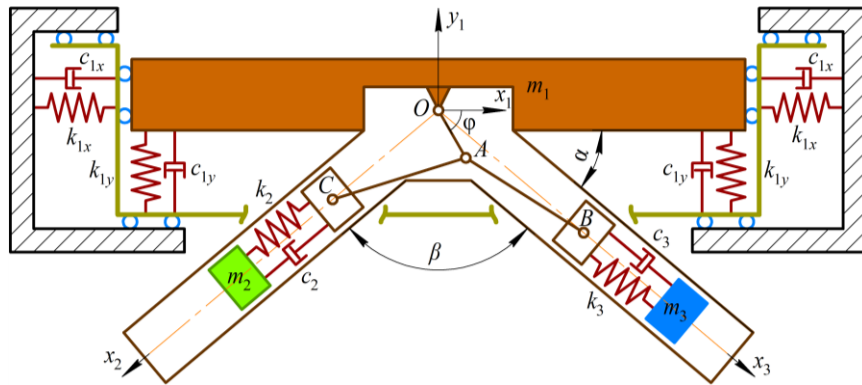

Fig. 17. Dynamic model of the vibratory system [16]

The considered vibratory system with five degrees of freedom is presented in Fig. 17. The dynamic scheme of the conveyor's vibratory system comprises three movable bodies with corresponding inertial parameters defined by their masses m_1 , m_2 , and m_3 . The system's working member, such as a conveying tray, screen, or sieve, undergoes oscillatory motion driven by the rotation of the crank OA , which induces rectilinear vibrations of the masses m_2 and m_3 along the axes Ox_2 , and Ox_3 , respectively. To constrain the angular oscillations of the working member (m_1), it is elastically mounted on a movable platform supported by independent spring-damper elements. These elements, positioned vertically and horizontally, are characterized by stiffness coefficients k_{1x} , k_{1y} and damping coefficients c_{1x} , c_{1y} , ensuring stability and controlled oscillations. The mechanism offers multi-mode control of linear, elliptical, circular oscillation

trajectories. Its design allows for the adjustment of dynamic parameters to meet specific technological requirements. The relative motion of the excitation mechanism is represented by the angular position φ of the crank OA with respect to the horizontal axis Ox_1 . The horizontal and vertical vibrations of the working member (m_1) are defined by the displacements x_1 and y_1 . Thus, the motion of the system can be comprehensively modeled using five coupled differential equations, which describe the interactions between the rectilinear and angular oscillations of the components.

Fig. 18 illustrates the trajectories of the working member vibrations obtained by analyzing the system's kinematics and dynamics under varying angles α and β . The geometric, inertial, stiffness, and damping parameters of the conveyor were substituted into the system of differential equations (Eq.1 - 4 in [16]), and the corresponding numerical solution was derived using the Runge-Kutta methods in Mathematica software. The “ExplicitRungeKutta” function, integrated with a proportional-integral step-size controller, was used to solve the stiff and quasi-stiff systems, while the “ParametricNDSolve” function allowed for solving the ordinary differential equations with respect to time for different parametric values of α and β .

The trajectories depicted in Fig. 18 correspond to the following parameter values: $\alpha = 0^\circ, 30^\circ$ and $\beta = 0^\circ, 30^\circ, 60^\circ, 90^\circ, 120^\circ, 150^\circ$ and 180° , demonstrating the influence of these angles on the vibratory motion of the working member. The obtained results highlight how variations in α and β enable trajectory control, reflecting the system's adaptability to diverse operational conditions. The ability to adjust the angle β enables the working member to perform rectilinear, elliptical, or circular oscillations. Specifically, rectilinear oscillations occur at $\beta = 0^\circ$ and $\beta = 180^\circ$, while circular oscillations are observed at $\beta = 90^\circ$. For all other β -values, the working member exhibits elliptical trajectories (see Fig. 18). The shape of the ellipse is characterized by parameters such as focal distance, eccentricity, and the ratio between the minor and major axes, as well as the vibration characteristics, which are influenced by the value of β . The elliptical trajectories provide the rightward conveying of materials when β in the range of from 0 to 90° and $\alpha = 0^\circ$. Whereas leftward conveying occurs in the range from 90° to 180° . To alter the direction of the rectilinear oscillations, it is necessary to adjust the angle α . Thus, the implementation of a controllable twin crank-slider excitation mechanism provides enhanced flexibility for modifying the vibration parameters and trajectories of the working member, ensuring adaptability for various operational requirements.

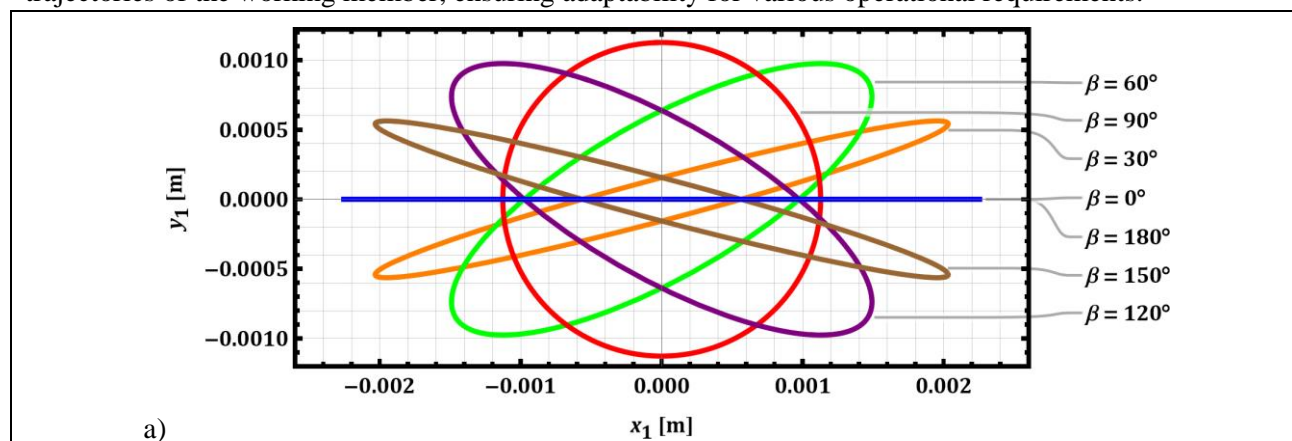

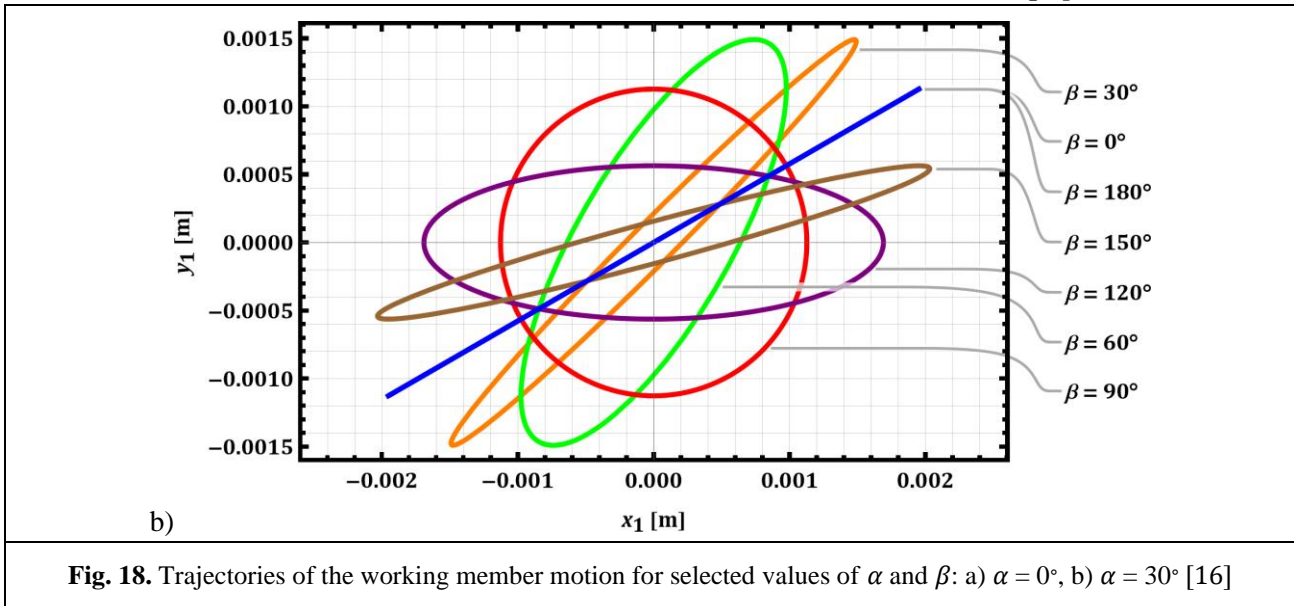

The Fig.19 illustrates the time dependencies of the vibration intensity factor W and vertical acceleration y of the working member at various angular positions β and different values of α [16]. The curves demonstrate how angular parameters α and β influence the oscillation intensity and vertical acceleration of the working member. This figure validates the system's adaptability and its ability to generate specific vibration characteristics by adjusting the angular parameters, which is essential for tailoring performance to various operational requirements. Lagrange-d'Alembert principle, used to derive a mathematical model, describing the system's dynamics. Numerical modeling conducted in Mathematica with the Runge-Kutta methods demonstrated the feasibility of achieving these tailored oscillations [16]. Time response curves and vibration trajectories are presented to validate the system's dynamic capabilities.

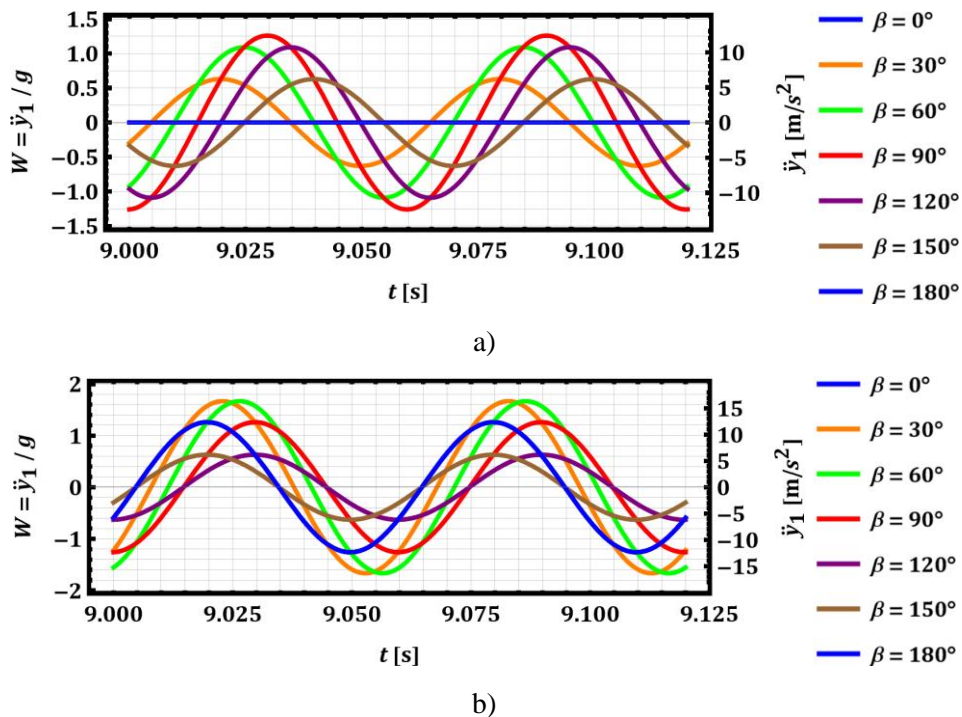

It was established that the proposed twin crank-slider excitation mechanism is suitable for changing

the vibratory conveyer dynamic parameters in accordance with the specific technological requirements and enhances the operational flexibility and efficiency of vibratory equipment. By allowing precise control over vibration trajectories and amplitudes, this mechanism addresses the challenges of modern vibratory systems. This approach enhances the adaptability and efficiency of vibratory systems, making it particularly suitable for applications such as conveyors, sieves, and compactors. By fine-tuning geometric and operational parameters, the proposed mechanism effectively addresses the challenges posed by modern industrial requirements. The results demonstrate the system's flexibility in controlling vibration trajectories and highlight the significant impact of geometric parameters on its overall performance. By adjusting these parameters, the system demonstrates adaptability and precise control, enabling tailored vibration characteristics for diverse operational needs.

By identifying critical conditions for minimizing reaction forces and counter-torque, research [17] provides a foundation for the design of advanced vibration exciters. These contributions are essential for enhancing the adaptability and energy efficiency of vibratory systems in industrial applications. Further development of the theoretical framework for synthesizing geometric parameters of slider-crank mechanisms ensures specific trajectories, such as elliptical or circular, which are critical for the effective operation of vibratory equipment. The derived equations allow designers to calculate the geometric parameters required to achieve desired motion trajectories.

Fig. 20 illustrates the basic setup of the twin crank-type mechanism [17]. It shows the working member (m_1) suspended by spring-damper elements and the crank mechanism OA connected to sliders B and C . The directions of motion and angular positions (α , β) of the sliders are highlighted, forming the foundation for analyzing the dynamic and kinematic behavior.

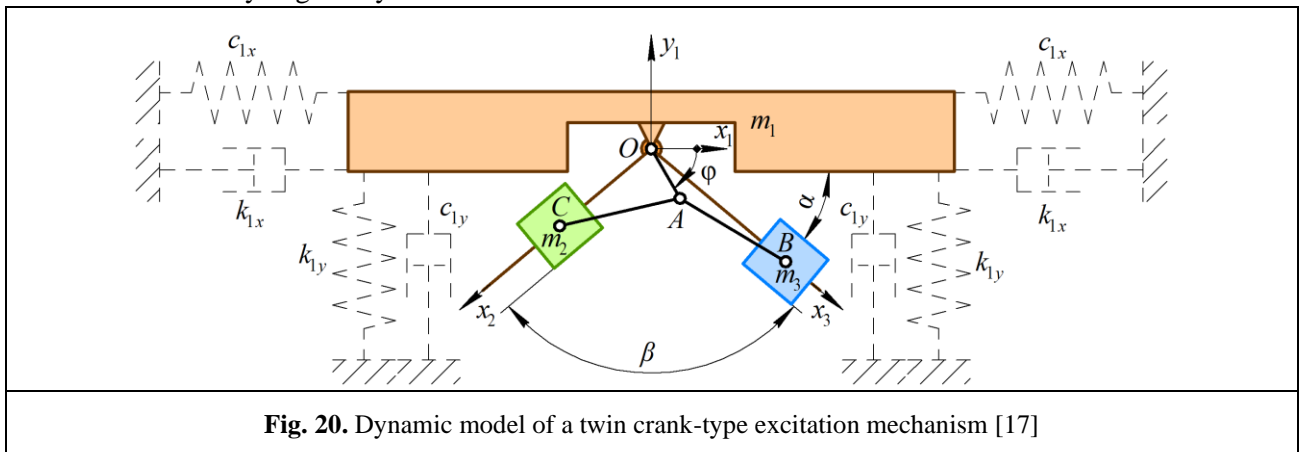
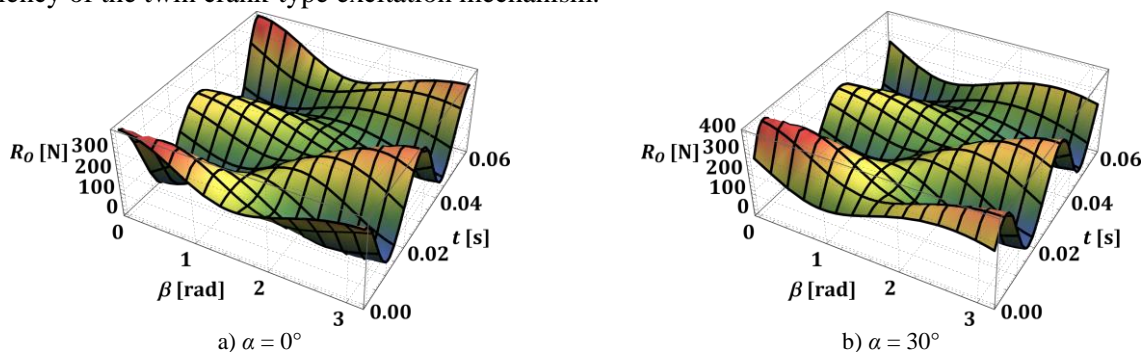

Fig. 21 illustrates the time-dependent variation of reaction forces at the crank hinge for different angular configurations (α and β) [17]. The data shows peak reaction forces ranging from 390 to 410 N under specific conditions and highlights a significant reduction in forces. These results underscore the importance of optimizing angular parameters to minimize reaction forces, enhancing the stability and efficiency of the twin crank-type excitation mechanism.



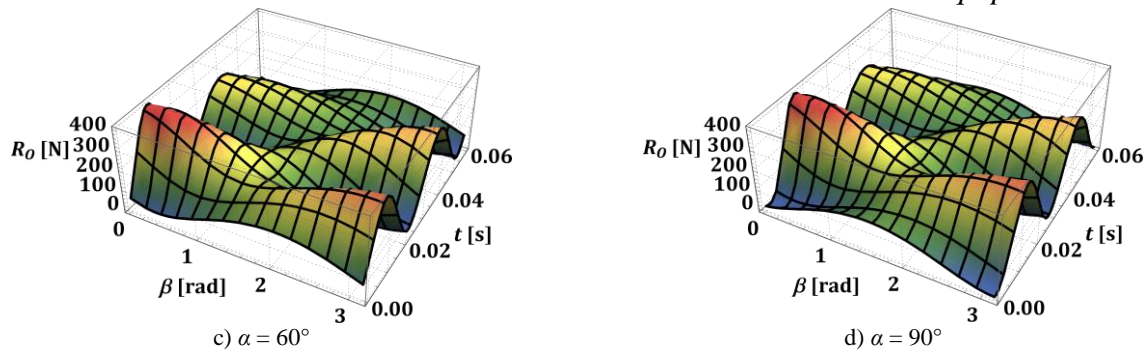

Fig. 21. Reaction force - time dependencies at different α and β angles in the central hinge [17]

The analyzed study highlights the importance of twin crank-type mechanisms in enhancing the performance of vibratory technological machines. The research focuses on deriving analytical expressions to describe the inertial forces, reaction forces, and antitorque moments acting upon the components of the mechanism under varying operational conditions and design parameters, what provides a robust foundation for optimizing the dynamic and strength characteristics of vibratory equipment.

Conclusions

This research offers detailed insights into innovative designs for vibration exciters, focusing on planetary and twin crank-slider mechanisms to address critical challenges in modern vibratory systems. The symmetric planetary-type mechanism was shown to generate complex oscillation trajectories, including triangular and hexagonal paths, while maintaining operational stability and precision. Additionally, the self-regulating planetary exciter introduces adjustable inertial parameters, enhancing adaptability to diverse technological requirements. The twin crank-slider mechanism demonstrated its ability to optimize trajectory control, providing linear, elliptical, and circular motion tailored to specific industrial tasks.

Numerical modeling and simulations confirmed the feasibility of these designs, highlighting their potential to reduce energy consumption and ensure stable performance under varying conditions. The results provide a robust foundation for improving vibratory equipment used in material handling, sieving, and compacting processes. Future studies should focus on experimental validation and real-world implementation of these mechanisms, further refining their parameters to expand their application range and operational efficiency.

References

- [1] V. O. Povidailo, "Vibratsiini protsesy ta obladnannia," [*Vibration processes and equipment*]. Lviv, Ukraine: Vyd-vo Nats. un-tu "Lvivska politehnika", 2004, pp. 1–248. [in Ukrainian].
- [2] I.P. Zabrodets, M.P. Yaroshevych, and A.V. Sylyvoniuk, "Doslidzhennia puskovykh rezhymiv vibratsiinoi mashyny z debalansnymy zbudnykamy, shcho samosynkhrizuiutsia" ["Investigation of startup modes of a vibratory machine with self-synchronizing unbalanced exciters"], *Avtomatyzatsiia vyrobnychkykh protsesiv u mashynobuduvanni ta pryladobuduvanni*, [Automation of production processes in mechanical engineering and instrument making] vol. 47, pp. 50–55, 2013. [in Ukrainian].
- [3] R. Palevičius and K. Ragulskis, "The self-resonance effect of the planetary vibration excitation systems," *Journal of Vibroengineering*, vol. 14, no. 1, pp. 244–249, 2012.
- [4] V. V. Mikheyev, "New type of vibration generator with vibratory force oriented in preferred direction," *Journal of Vibration Engineering and Technologies*, vol. 6, no. 2, pp. 149–154, 2018.

Vitaliy Korendiy, Andy Augousti, Olena Lanets, Taras Vilchynskiy, Vladyslav Kyrychuk,
Oleksandr Yaniv, Roman Protasov

- [5] V. V. Mikheyev and S. V. Saveliev, "Planetary adjustable vibratory exciter with chain gear," in *Journal of Physics: Conference Series*, vol. 1210, no. 1, p. 012097, 2019.
- [6] I. Lyan, K. Krestnikovskii, G. Panovko, and A. Shokhin, "Determination of mass-geometric characteristics of self-regulating debalance of an inertial vibration exciter," *Vibroengineering Procedia*, vol. 25, pp. 70–75, 2019.
- [7] M. Marek, G. Kustarev, and N. Andriuchov, "Theoretical studies and conditions analysis of the inertial slider slippage of asymmetric planetary vibration exciter for snowplow," *Bulletin of D. Serikbayev EKTU*, no. 3, pp. 63–78, 2021.
- [8] G. F. Alışverişçi, "The nonlinear behavior of vibrational conveyers with single-mass crank-and-rod exciters," *Mathematical Problems in Engineering*, vol. 2012, pp. 1-17, 2012.
- [9] M. Buzzoni, M. Battarra, E. Mucchi, and G. Dalpiaz, "Motion analysis of a linear vibratory feeder: Dynamic modeling and experimental verification," *Mechanism and Machine Theory*, vol. 114, pp. 98–110, 2017.
- [10] W. Zhang, Z. Liu, W. Liu, J. Sun, and H. Lu, "Dimensional synthesis of a spherical linkage crank slider mechanism for motion generation using an optimization algorithm," *Mechanical Sciences*, Vol. 14, pp. 125–142, 2023.
- [11] V. Korendiy, V. Gurey, V. Borovets, O. Kotsiumbas, and V. Lozynskyy, "Generating various motion paths of single-mass vibratory system equipped with symmetric planetary-type vibration exciter," *Vibroengineering Procedia*, vol. 43, pp. 7–13, 2022.
- [12] V. Korendiy, O. Parashchyn, V. Heletiy, V. Pasika, V. Gurey, and N. Maherus, "Kinematic analysis and geometrical parameters justification of a planetary-type mechanism for actuating an inertial vibration exciter," *Vibroengineering Procedia*, vol. 52, pp. 35–41, 2023.
- [13] V. Korendiy, I. Kuzio, S. Nikipchuk, O. Kotsiumbas, and P. Dmyterko, "On the dynamic behaviour of an asymmetric self-regulated planetary-type vibration exciter," *Vibroengineering Procedia*, vol. 42, pp. 7–13, 2022.
- [14] V. Korendiy, O. Parashchyn, A. Stetsko, R. Litvin, O. Kotsiumbas, and R. Pelo, "Force analysis of the planetary-type mechanisms of the enhanced vibration exciters," *Vibroengineering Procedia*, vol. 54, pp. 28–34, Apr. 2024.
- [15] V. Korendiy, T. Vilchynskiy, V. Lozynskyy, R. Kachmar, Y. Porokhovskiy, and R. Litvin, "Trajectory-based synthesis of a slider-crank mechanism for applications in inertial vibration exciters," *Vibroengineering Procedia*, vol. 56, pp. 176–182, 2024.
- [16] V. Korendiy, V. Gursky, P. Krot, and O. Kachur, "Dynamic analysis of three-mass vibratory system with twin crank-slider excitation mechanism," *Vibrations in Physical Systems*, vol. 34, issue 2, pp. 2023226, 2023.
- [17] V. Korendiy, R. Predko, Y. Danylo, O. Yaniv, "Analysis of the force and power characteristics of a twin crank-type mechanism of an enhanced vibration exciter," *Vibroengineering Procedia*, vol. 55, pp. 1–7, 2024.