

Entropy-Based Opportunistic Spectrum Access Algorithm in Cognitive Radio Networks

Mahdi Pirmoradian, Student Member, IEEE, Christos Politis, Senior Member, IEEE

WMN Research Group Kingston University

London, UK

{m.pirmoradian, c.politis}@kingston.ac.uk

Abstract- In this paper, we propose an opportunistic channel access scheme based on weighted residual entropy function in cognitive radio networks. This central decision scheme significantly improves spectrum utilization compared with random and first opportunistic spectrum access schemes. Particularly, in this mechanism, appropriate spectrum opportunity will be selected based on the usefulness of idle channel's lifetime, which will be estimated through weighted residual entropy function of available licensed channels. We show that performance of the proposed spectrum decision technique in terms of channel utilization, channel collision and spectrum handoff rate are efficient in period of simulation time (1s). The simulation results confirm that the proposed Maximum Entropy Channel Access (MECA) scheme would be a viable spectrum decision technique in terms of channel utilization and energy consumption when compared with Random Channel Access (RCA), First Opportunistic Channel Access (FOCA), and Maximum Remaining Lifetime (MRL) schemes.

Keywords— Channel Access, Cognitive Radio, Residual Entropy, Spectrum Utilization

I. INTRODUCTION

Spectrum has become a scarce radio resource in emerging wireless technologies due to the proliferation of short-range wireless communication systems, the current static spectrum

allocation mechanisms, and the rise of user's demand associated with the increase in the volume of data transmission over multimedia mobile networks, which is estimated to be doubled every year [1]. To overcome this crucial challenge, efficient use of underutilized frequency bands need to be considered in the forthcoming advance wireless technologies. Recently, measurements from Spectrum Policy Task Force (SPTF) have shown that 85% of radio frequency bands are either partially or completely unused at different given times and geographical areas [1], [2]. For these reasons, experts are interested in providing sophisticated spectrum utilization and spectrum policy techniques, called dynamic spectrum allocation. This mechanism allows wireless equipment to interact with multi-standard networks in order to share unused radio spectrum bands, resulting in the efficient use of the underutilised radio spectrum portions. Different spectrum sharing models such as hierarchical spectrum access, Overlay Spectrum Access (OSA), and Underlay Spectrum Access (USA) have been proposed and studied in [3], [4].

Cognitive Radio (CR) concept, firstly presented by Mitola [5], has the potential to dramatically increase the efficient use of radio spectrums by allowing Secondary Users (SUs) or license-exempt users access to the unoccupied licensed spectrum bands, without causing interference with the primary transmission in an opportunistic manner. To achieve this aim, the SUs are responsible for monitoring each licensed channel usage pattern to identify and exploit interim spectrum opportunities (spectrum holes) in an efficient way. Also SUs must monitor and predict returning of the PUs in current operating channel and so promptly cease transmission and vacate the operating band.

Dynamic Spectrum Access (DSA) or Dynamic Spectrum Management (DSM) is given as main capability of cognitive devices. The predominant features of the DSA approach are spectrum sensing, spectrum analysis, spectrum decision, and spectrum mobility functionalities [3], [4], [6]. Spectrum decision is the process of assigning appropriate

available idle channels based on the internal and external radio characteristics by employing diverse regulatory policies. This process can be implemented either in centralized or distributed approach. Also, the decision can be made based on the cooperative or non-cooperative mechanisms. Different spectrum decision techniques, using sensing results and statistic characteristics of the radio environment such as; remaining idle channel lifetime, probability of channel collision, and the probability of PU's appearance have been studied in many research works [7], [8], [9], [10], [11]. However, they have not considered entropy of the remaining idle channels into the decision process to find suitable spectrum hole (channel) for secondary data delivery.

In this work, we consider a dynamic system, where a typical secondary network seeks and selects an available idle channel through the weighted residual entropy scheme. The proposed mechanism evaluates the usefulness of the remaining idle channels' lifetimes and allocates suitable channel for secondary transmission based on the central decision approach.

Hence, the acquired decision reveals which channel is suitable and when it is able to deliver a high quality and reliable secondary data among unoccupied licensed channels in the proposed dynamic system. In this case, an appropriate idle channel would be selected through the evaluated usefulness of the vacant channels at time instance t . Our contributions are: 1) whether weighted residual entropy can be employed to evaluate and allocate spectrum holes in cognitive radio networks supporting multi-licensed channels? and 2) The viability assessment of the proposed scheme would be compared with predecessor channel access schemes such as RCA, FOCA, and MRL schemes [10], [12], [13]. Moreover, the weighted residual entropy gives the usefulness of the secondary data transmission in the remaining channel lifetime.

The rest of the paper is structured as follows. Section II, explains related work. In section III, system topology, network assumptions, and mathematical analysis are illustrated. Section IV,

describes spectrum hole allocation procedure and sequence diagram of the proposed scheme. Different employed spectrum decision techniques are explained in section V. In section VI, performance and justification metrics are introduced. The numerical results of MECA scheme and their comparisons with RCA, FOCA, and MRL schemes are presented in section VII, and eventually conclusion and future concepts in section VIII.

II. RELATED WORK

To deal with the challenges in focus in this paper and build a solid foundation for future work on spectrum optimization, the most relevant research topics on spectrum decision and spectrum selection are reviewed as follows: In [7], authors present different OSA schemes called spectrum-matching algorithms, which are based on the statistical characteristics of spectrum bands, the probability density function of unoccupied channels has been taken into channel selection strategy to provide QoS of the SUs. A spectrum hole prediction model based on the IEEE 802.11 standard is introduced in [8]. In this case, the distribution of Interval between Two Consecutive Packets (ITCP) in multi user networks is analysed, and the proposed spectrum hole prediction strategy is evaluated based on the estimated probability density functions. Moreover in [10], a dynamic channel selection scheme for agile low power wireless packet switched networks is presented over unlicensed bands with application on short-range wireless communications. In this model, the appropriate channel and future-operating channel are predicted by using data history of transmissions in all channels. Hence, two channel selection mechanisms namely, Minimum Collision Rate Algorithm (MCRA) and Minimum Handoff Rate Algorithm (MHRA) are proposed in [11]. These algorithms explore suitable unoccupied licensed channels considering minimum average channel collision and minimum spectrum handoff rate in reactive and proactive sensing manner. Based on the simulation results, it can be seen that MCRA scheme shows great performance compared to MHRA in low latency handoff situation. In addition, a

voluntary spectrum handoff mechanism based on the transition probability of licensed channels' states, and idle channel lifetime are proposed in [14]. However the aforementioned publications did not consider application of entropy in finding appropriate interim spectrum opportunity in dynamic wireless networks.

III. SYSTEM MODEL AND CONCEPTS

This section illustrates the proposed system topology, channel modeling, weighted residual entropy function concept, and idle channel remaining lifetime. We consider, an open licensed spectrum network with several static wireless nodes, which communicate with each other using N licensed channels, whilst, a multi-users cognitive radio network is located within licensed coverage area, meanwhile, the secondary network is able to monitor and use licensed channels in an opportunistic manner. Particularly, secondary users are assumed to be static and equipped by spectrum sensor.

The networks are assumed to be packet switched with variable data packet size. Also the cognitive nodes response to observe and report channel states' information to the central node via dedicated common control channel. Also, each sensor provides a sequence of 1/0 binary signal, which represents vacancy and occupancy of each licensed channel, at time instance t . The SUs start sensing the available channels upon receive sensing request signal from Central Node (CN), and so the decision process is to be preceded as soon as CN collects channel states' information. The network notations and employed parameters are explained in table 1.

A. Licensed Channel Usage

Perceiving, analysing, processing and predicting of the interim unused spectrum portions in both frequency and time domains require highly computational mathematical techniques. The utilisation of the licensed bands by the PU can be modelled as a Poisson process with arrival rate parameter m , therefore, the number of events in time interval $(t, t + t]$ can be given by [9];

$$P[(N(t + t) - N(t)) = k] = \frac{(mt)^k e^{-mt}}{k!} \quad k = 0, 1, 2, \dots \quad (1)$$

Here $N(t + t) - N(t)$ is the number of events in time interval $(t, t + t]$. A single duration of utilisation of the licensed band by a PU is denoted by T_{on} and a single duration of the licensed band being idle (unoccupied) is denoted by T_{off} . The duration between two utilization periods (inter-arrival rate of the PU) are identical independent distribution (i.i.d) random variables following an exponential distribution with constant busy and idle periods during system analysis. Therefore an efficient implementation of dynamic spectrum observation and allocation, significantly improves spectrum utilization and the reliability of the secondary user transmission. Consequently, the probability density function of OFF and ON states (duration of unoccupied and occupied times) for licensed channel k can be expressed as [15]:

$$f_{TZ}^k(t, m_Z) = m_Z^k e^{-m_Z t}, t \geq 0 \quad (2)$$

In the expressions above, Z can be defined as OFF or ON states and, μ denotes OFF and ON states arrival rates. It is assumed that the arrival rates and probability density functions that can be estimated by the existing methods [16] are known to the SUs. The period of the OFF state are directly linked to the quality of the SU transmission over available channels. For simplicity, in the rest of the article ON and OFF states are replaced by X and Y random

variables respectively (see Figure 1), and Z denotes the remaining lifetime of the idle channel at sensing time instance [17], [18].

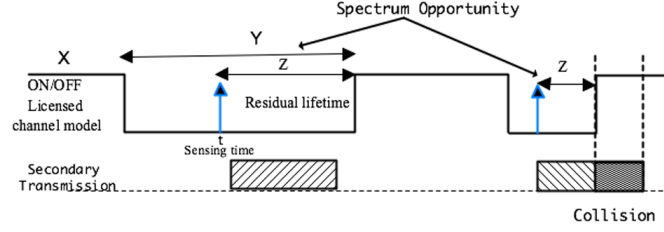

Figure 1: Primary user channel model; Y and X are identical independent random variables, and Z represents idle channel residual lifetime.

B. Preliminary of Residual Entropy Concept

The notion of entropy was originally developed by physicist in the context of equilibrium thermodynamics and later extended through the development of statistical mechanics. Also, in 1948, Shannon introduced the concept of entropy into the information theory. In this context, entropy is a measure of the uncertainty associated with a random variable. Let assume X be a random variable having an absolutely continuous distribution function F with probability density function f , then the entropy of the random variable X is defined as,

$$H(X) = - \int_0^{\infty} f_X(x) \log f_X(x) dx \quad (3)$$

Moreover, the concept of residual entropy in terms of conditional Shannon measure was introduced in [19], where the residual entropy at a time t of a random lifetime X is defined as the differential entropy of $(X/X > t)$. Basically, for all $t > 0$, the residual entropy of X is given by [19],

$$H(X;t) = - \int_t^{\infty} \frac{f_X(x)}{F_X(x)} \log \frac{f_X(x)}{F_X(x)} dx \quad (4)$$

Where $\frac{f_X(x)}{F_X(x)}$, $F(t) = P(X > t)$ denote the hazard function and survival function of X respectively. Given that an item has survived up to t , $H(X;t)$ measures the uncertainty of the

remaining lifetime of the component. Such an information measurement does not take into account the values of the random variable but only its probability density. Hence the use of this type of entropy has the drawback of being position free, meaning that a random variable X obtains the same Shannon entropy as $X+b$ for any $b \in \mathbb{R}$.

In [20], author proposes the notion of weighted residual entropy to cope with the position free issue of a random variable. The weighted residual entropy at time t of a random lifetime X is the differential weighted entropy of $[X | X > t]$ that is given by;

$$H^w(X;t) = - \int_t^{\infty} x \frac{f_X(x)}{F_X(t)} \log \frac{f_X(x)}{F_X(t)} dx \quad (5)$$

The factor x , in the integral on the right-hand-side of equation (5), may be viewed as a weight that linearly emphasizes the importance of the occurrence of the event $\{X = x\}$. This yields a “length biased” shift-dependent information measure, assigning greater importance to larger values of X . Here, given that an idle channel state is random variable, which has survived up to time t , $H^w(X;t)$ could represent the characteristic of the remaining life time of the spectrum hole. In fact, higher value of the weight residual entropy represents appropriateness of the spectrum hole lifetime. This attribute could be considered as a key stakeholder in spectrum hole selection strategy in multichannel dynamic systems. Also, the use of weight entropy in wireless communication reveals the usefulness of events by means of information measurement [20], [21].

Here the channel OFF state is exponential random variable with parameter $m_{off} > 0$, therefore, by replacing (2) into (5) the weighted residual entropy function of an exponential random lifetime can be given by,

$$H^w(X;t) = - \int_t^{\infty} x \frac{m_{off} e^{-m_{off}x}}{e^{-m_{off}t}} \log \frac{m_{off} e^{-m_{off}x}}{e^{-m_{off}t}} dx = t + \frac{2}{m_{off}} - \left(t + \frac{1}{m_{off}}\right) \log m_{off} \quad t > 0 \quad (6)$$

(Proof. See Appendix)

Here t represents either the idle channel survival lifetime or sensing time instance. We consider (6) as an important metric to estimate usefulness of observed spectrum holes at sensing time instance, and so larger value of weighted residual entropy confirms usefulness of the excess spectrum hole lifetime.

C. Idle Channel Remaining Lifetime

This subsection provides brief explanation on the estimation of remaining idle channel lifetime, based on the alternative renewal theory [13]. We assume licensed channel model follows a two state repairable system with i.i.d random variable states (X and Y in figure 1). In this system, the functioning period and the system down time for the repair period are random variables. Hence the sequence of random variables $\{Y_i+X_i \mid i=1,2,\dots\}$ are mutually independent and identically distributed. Thus the remaining idle channel lifetime at sensing time instance t in channel i can be obtained as [22],

$$E(Z^i(t)) = \frac{\eta_{on}^i + \eta_{off}^i}{\eta_{on}^i \eta_{off}^i} - t \exp[-(\eta_{on}^i + \eta_{off}^i)t] \quad (7)$$

Where Z and t represent idle channel lifetime and sensing time instance.

IV. SPECTRUM HOLE OBSERVATION PROCESS

This section illustrates our proposed spectrum decision scheme, which closely reflects the system model discussed in the previous section. The procedure explores and allocates an appropriate channel at time instance t , through the central decision approach. The sequence diagram of the proposed spectrum selection algorithm is presented in figure 2. Clearly, the proposed algorithm at the CN runs when SUs require an unoccupied channel to communicate with each other. The following are the prominent actions taken by the procedure.

- 1) The SU which desires to transmit data sends channel-request signal to the CN.
- 2) The CN confirms the request signal, informing available SUs and local sensing task to perform sensing and report back the status of the available channels to CN. The CN is responsible for

the following tasks in order to find the appropriate unoccupied channel in an efficient way.

- *OR rule diffusion* applies on each set of reported channel's states.
- A set of vacant channels is provided to the *entropy-based* evaluation task.
- An appropriate vacant channel is recognized and identified through entropy task.
- The selected channel will be established to the target SU.

Basically, low decision delay, low energy consumption, and low complexity are the main predominant features of the central decision mechanisms in comparison with distributed spectrum decision mechanisms.

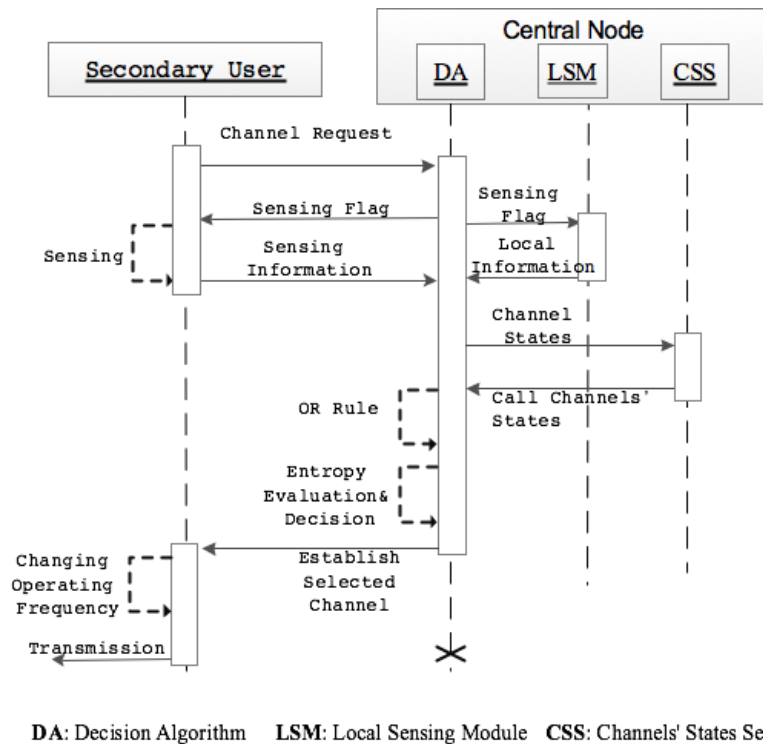

Figure 2. Sequence diagram. Cognitive Users request unoccupied channel by sending channel request signal to Central Node (CN) at time t.

V. SPECTRUM DECISION TECHNIQUES

In this section, four examined spectrum decision techniques namely; Maximum weighted residual entropy, random channel access, first opportunistic channel access and maximum remaining idle channel lifetime are illuminated.

A. Maximum Entropy-based Channel Access (MECA) Mechanism

As explained earlier, this channel access mechanism relies on weighted residual entropy lifetime of the unoccupied licensed channels at time instance t . The reported channel states information from spectrum sensors and licensed channel's characteristics have taken consideration into equation (6), to discover and allocate an appropriate vacant channels. In principle, the maximum weighted residual entropy lifetime could be expressed as the usefulness of the spectrum hole. This spectrum selection strategy can be implemented based on the following algorithm.

$$SH_j^{MECA}(t) = \operatorname{argmax}\{i \mid H_i^w(X;t)\} \hat{\cap} N(t) \quad (8)$$

Here SH_j denotes the selected opportunity in idle channel j , and i represents a sequence number of unoccupied licensed channels at time instance t . The above definition illustrates that an appropriate spectrum hole is located in the unoccupied channel has maximum weighted residual entropy at time t .

B. Random Channel Access (RCA) Mechanism

In this technique, spectrum holes are discovered and selected from unoccupied channel's set, which contains all available spectrum opportunities at time t . The procedure is implemented under uniform channel access probability. This spectrum selection mechanism can be expressed by;

$$SH_j^{RCA}(t) = \operatorname{random}\{i \mid i \hat{\cap} N(t)\}, \quad 0 \in i \in N \quad (9)$$

Where $i=0$, shows that all licensed channels are occupied at time t .

C. First Opportunity Channel Access (FOCA) Mechanism

In this scheme, the first observed unoccupied channel would be exploited as an appropriate spectrum hole. In this case, available channels will be sensed in progressive manner (from

channel 1 to N). Thus sensing and exploration times are small compared with RCA and MECA, and MRL schemes. Therefore, the spectrum decision scheme can be given as;

$$SH_j^{FOCA}(t) = \min\{i | i \in N(t)\}, 1 \leq i \leq N \& i = \inf; \text{ if channel is occupied} \quad (10)$$

Where j represents appropriate unoccupied channel at time t and i denotes sequence number of vacant channels at time instance t .

D. Maximum Remaining Lifetime (MRL) Scheme

MRL scheme has been studied in previous researches and considered as an appropriate spectrum hole selection scheme in dynamic systems. The main goal of this scheme is to enhance secondary data delivery and decrease spectrum handoff, and as much as possible by selecting reliable spectrum hole. This scheme estimates the remaining lifetime of the unoccupied licensed channels using channels' characteristics, and so the channel with maximum remaining lifetime is allocated to the SU for data delivery. This spectrum decision strategy can be expressed as;

$$SH_j^{MRL}(t) = \arg \max\{i | E(Z^i(t)), i \in N(t)\} \quad (11)$$

VI. PERFORMANCE METRICS

A. Channel Usage Estimation

The SUs desire access to the idle licensed channels at a time instance t . Therefore the remaining lifetime of the idle channel plays a key stakeholder in the reliability of data transmission at the both SU and PU sides. The SU's transmission time is assumed to be fix during system working. According to the nature of the channel usage model and characteristics of random variables, the average secondary use of a typical operating channel can be written as;

$$E = L_{su} \int_{L_{su}}^{\infty} f_X(x) dx + \int_0^{L_{su}} x f_X(x) dx \quad (12)$$

Here L_{su} , denotes secondary delivery time, which is defined by either standard body or user.

The first item in the right hand side of equation (12) shows the probability of successful transmission and the second item represents the probability of either unsuccessfully transmission or collision.

B. Average Channel Utilization

The proposed network topology consists of multi-licensed channels, where SUs are permitted to access and utilize licensed channels opportunistically. We assume the average channel utilization in channel j in period of time $[0, T]$, is given by,

$$CU_{av}^j = \lim_{T \rightarrow \infty} \frac{\text{Total duration of the SU transmission over channel } j \text{ in } [0, T]}{T} \quad (13)$$

The expression above is expected to be reached at maximum channel utilization equal to

$$\frac{E(X_j)}{E(X_j) + E(Y_j)},$$

meaning that secondary user fulfills all OFF states. By substituting (12) into (13)

the secondary channel utilization in channel j for specific period of time T can be rewritten by;

$$CU_{av}^j \% = \frac{E \cdot \sum_{n=0}^{N-1} W_j(t_n)}{T} \times 100\% \quad (14)$$

Here $W_j(t)$ is sequence binary signal and denotes channel selection state given by,

$$W_j(t_n) = \begin{cases} 1, & \text{If channel } j \text{ is allocated to the SU} \\ 0, & \text{If channel } j \text{ is occupied by PU} \end{cases}$$

C. Average Channel Collision

In a realistic world, secondary transmission over elected channels may causes interference to primary transmission because of the failure in channel selection process or the appearance of licensed users while SU transmits. Also, collision may occur whenever secondary transmitters are unable to detect acknowledgement signals of its receiver regarding radio

environment noise and channel detection error. In this article, collision is calculated on the secondary user's side. This metric denotes performance of the secondary channel access and will be evaluated through proposed spectrum opportunity access schemes. Assuming the data fusion OR rule at the CN performs perfectly, then the average unsuccessful SU transmission in channel j can be obtained from equation (12) by;

$$Co_{av}^j = \frac{1}{m_{off}^j} - (L_{su}^j + \frac{1}{m_{off}^j}) \exp(-m_{off}^j L_{su}^j) \quad (15)$$

Therefore, the Average Collision (AC) in specific period of time T in channel j can be expressed as;

$$AC_{av}^j(T)\% = \frac{Co_{av}^j \sum_{n=0}^{N-1} W_j(t_n)}{S^T L_{su}^j} \times 100\% \quad (16)$$

Here S^T denotes number of secondary transmission in the period of T .

D. Channel Handoff Rate

Spectrum handoff occurs when primary users are expected to reappear in used frequency band. When this happens, a secondary user must change its operating frequency to a new unoccupied channel as soon as possible. Basically, there is a direct link between spectrum hand off rate and SU power consumption, throughput and desired QoS, meaning that more spectrum handoff causes high power consumption as well as high transmission delay. Therefore, under the assumption of stationarity and ergodicity of the channels, we can define channel handoff rate at SU side in order to evaluate the performance of the proposed opportunistic spectrum access scheme as;

$$CHR_{av}^j\% = \lim_{T \rightarrow \infty} \frac{\text{Number of channel handoff in } [0, T]}{\text{Number of delivery time slot in } [0, T]} \times 100\% \quad (17)$$

The metrics above are considered to judge and compare performance of the proposed spectrum decision schemes.

VII. NUMERICAL RESULTS

In this section, we present the corresponding simulation results, which were generated using MATLAB. Lets assume a licensed network, which includes four-licensed channels with different channel rate characteristics $1/m_{off}$ and $1/m_{on}$ assumed to be (3, 1, 10 and 8) s and (2, 2, 2 and 1) s respectively. Also, the channel request signal would be sent to the CN randomly with the period of 1 to 5 seconds. All schemes' performances are evaluated in a specific time period of 5×10^3 s. In addition, the SU transmission time is assumed to be 1s, the sensing task and OR rule diffusion mechanism at the CN is expected to be perfect, and switching latency among channels is neglected. The proposed MECA algorithm and sensing task as part of the procedure are shown in the following

<i>Sensing Task at User j</i>	<i>Entropy-Based Spectrum Selection Task</i>
<pre> 1: Initialization inputs; N, $L_{su} = (50ms)$, $CSI_{i=1:N} = 0$ 2: For i=1 to N 3: Observes channel i 4: if channel i is vacant 5: $CSI_i^j = 1$ 6: Else 7: $CSI_i^j = 0$ 8: End if 9: End for 10: $SSF = 0$; Clear sensing signal flag 11: Send CSI_i^j to the CN 12: End task </pre>	<pre> 1: Initialization inputs; channel characteristics, Channel request flag $\leftarrow 1$ 2: $SSF = 1$ (Sensing Flag) 3: Call <i>sensing task</i> 4: Update $CSI_{i=1:N}^{j=1:M}$ 5: For i=1 to N 6: For j=1 to M 7: OR $CSI_i^{j=1:M}$; Run OR rule 8: End 9: End 10: Update $N(t)$ 11: If $(N(t) < > 0)$ 12: Evaluate $H_i^w(X;t), j \in N(t)$ 13: $SH_j^k(t) = \text{argmax}\{i H_i^w(X;t)\}, i \in N$ 14: Establish channel k to the target secondary user 15: Else 16: Establish no channel access 17: $T = \text{random}[1,5]$ s; Interval sensing time 18: End if 19: Go to (3) 20: End </pre>

In Figure 3, we evaluate the average channel utilization for four licensed channels through RCA, MECA, FOCA, and MRL schemes. The results obtained depict that MECA utilizes channels 3 and 4 much more than channel 1 and 2. On the other hand, MECA scheme targets

channel 3 and 4 for secondary data delivery. Subsequently, spectrum handoff is expected to be degraded compared with RCA, FOCA, and MRL schemes. The simulation results show that channel utilization based on MECA scheme peaks at 0.27% and 0.04% in channel 3 and 4 respectively. The graphs reveal that channel utilization through RCA scheme slightly spreads over four channels, while FOCA scheme reaches at 0.17%, 0.05%, in channels 1 and 2 approximately. In addition MRL peaks at 0.23%, 0.02% in channels 3 and 4. Comparing the obtained results, it can be seen that MECA scheme could be a more reliable spectrum decision scheme in terms of energy efficiency and handoff rate.

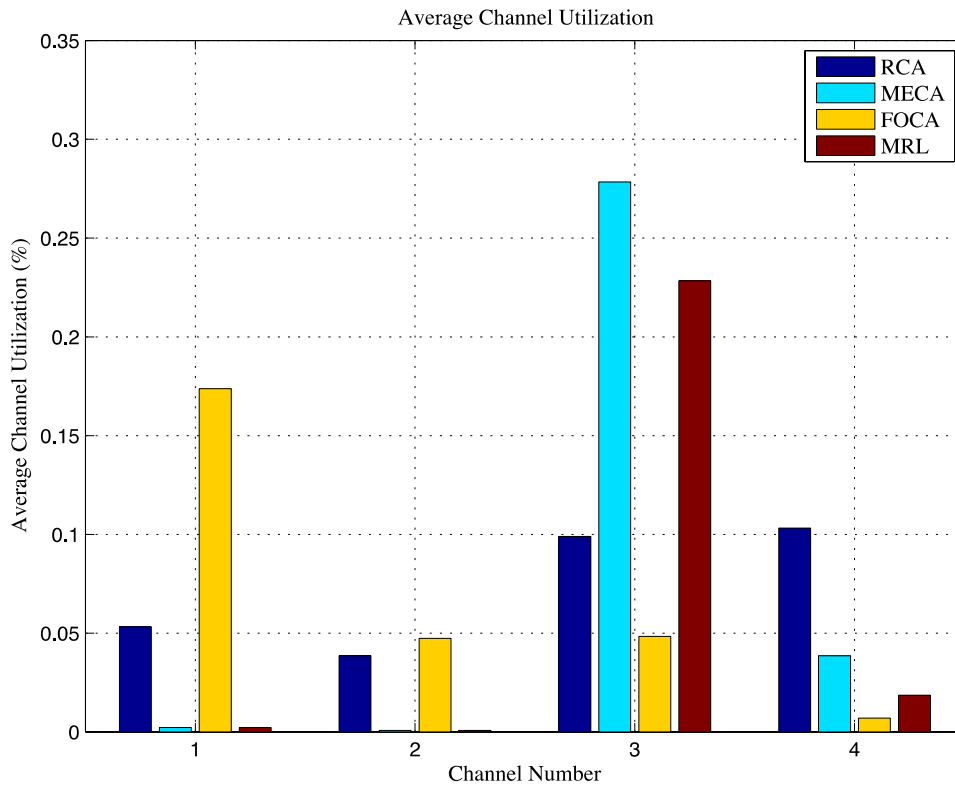

Figure 3. Average channel utilization in four licensed channel

Figure 4 shows the average channel collision in the four licensed channels for RCA, MECA, FOCA and MRL schemes in a time period of 5×10^3 s. The outcomes show that the maximum average channel collision peaks at 9% in channel 1, 3.7% in channel 3, 2.9% in channel 1, and 3.4% through application of FOCA, MRL, RCA, and MECA schemes. Clearly, channel 1

is influenced by high level of channel collision under FOCA scheme. While, as expected the channel collision slightly spreads in all channels for RCA scheme. Although MECA scheme slightly diminishes channel collision levels, but extremely supports a high level (Figure 3) of channel utilization when compared with MRL scheme. Thus, the numerical results confirm that MECA scheme can be a viable channel selection scheme in comparison to the RCA, FOCA and MRL schemes.

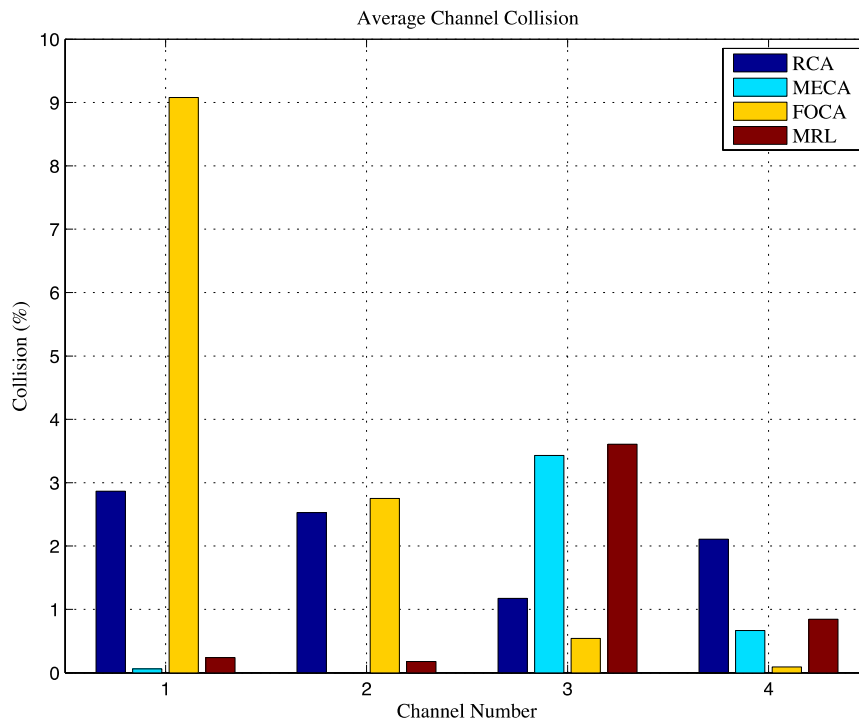

Figure 4. Average channel collision in four licensed channel in period of 5.0×10^3 s.

Figure 5 reveals the evaluation of the channel access rate for the aforementioned spectrum decision schemes within a time period of 5.0×10^3 s. The simulation results show that channel access rate peaks at 88% in channel 3 for the MECA scheme. While the channel access rate has values of at 60% and 89% in channel 1 and 3 for the FOCA and MRL schemes respectively. We see that the channel access rate of the MECA scheme is less than the channel access rate of the MRL scheme, in channels 3 and 4 while channel utilization of the MECA is greater than the MRL's channel utilization.

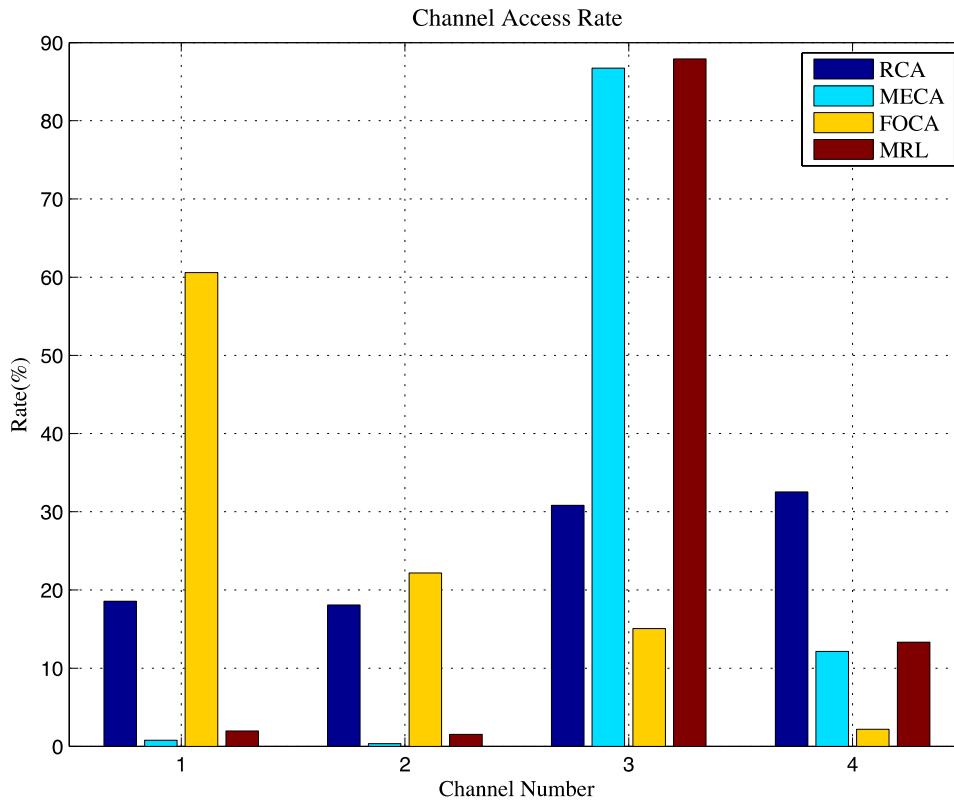

Figure 5. Licensed channel access rate

Channel collision probability is considered as the next performance metric for the proposed spectrum decision techniques. Figure 6 illustrates collision probability for RCA, MECA, FOCA, and MRL. The results reveal that MECA could be much more reliable with respect to the channel collision probability and channel access rate (figures 4 and 5). In MECA the maximum probability of collision peaks at 0.075 in channel 3, while FOCA and MRL peak at 0.18 and 0.082 in channel 1 and 3 respectively. Hence, MECA scheme allows secondary user to deliver its data with a low probability of collision in channels 3 and 4. In figure 7, we analysis and compare performance of the RCA scheme, the MECA scheme, the FOCA scheme, and the MRL scheme in the case of cumulative distribution function of the collision levels, in the primary channels 3 and 4. These channels are targeted by the MECA and MRL schemes. In plot (a) and (b), Cumulative Distribution Function (CDF) evaluations reveal the

probability of collision level for the MECA scheme is much less than its collision level for the MRL scheme.

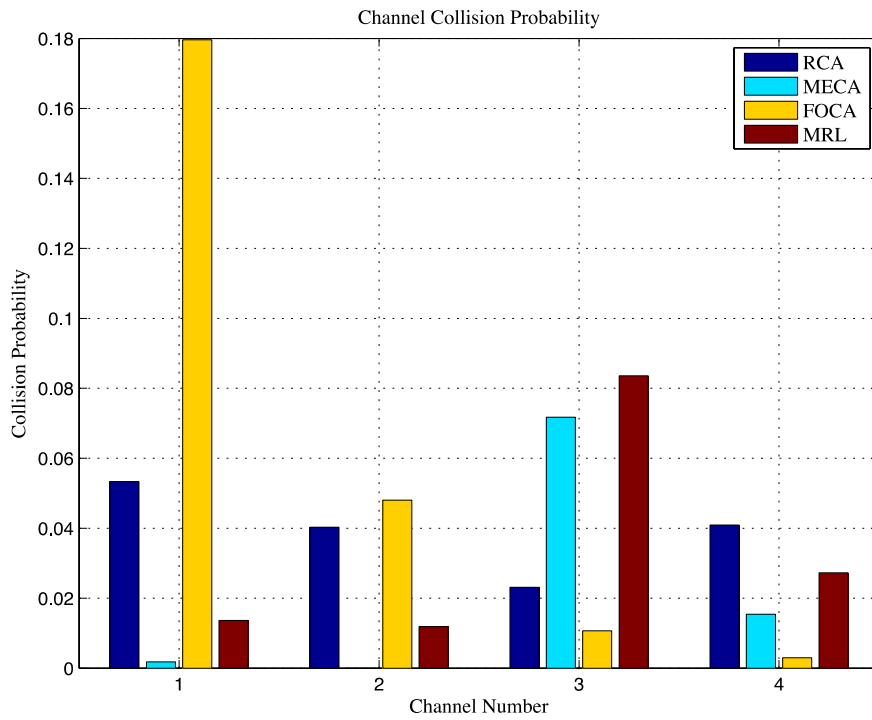
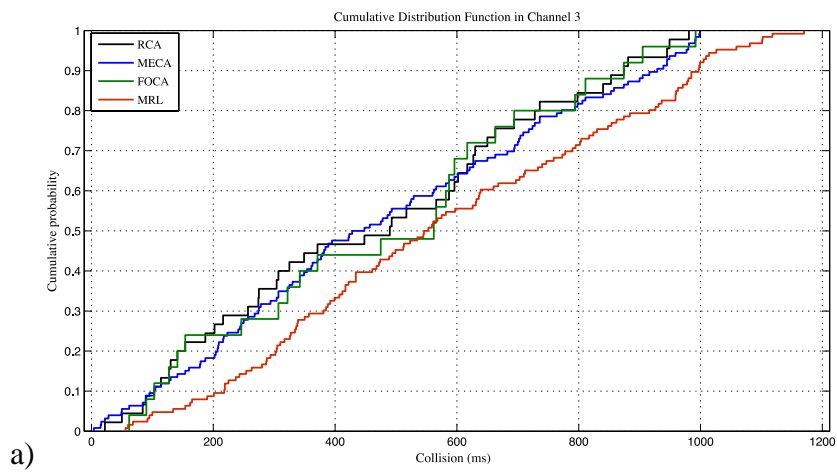
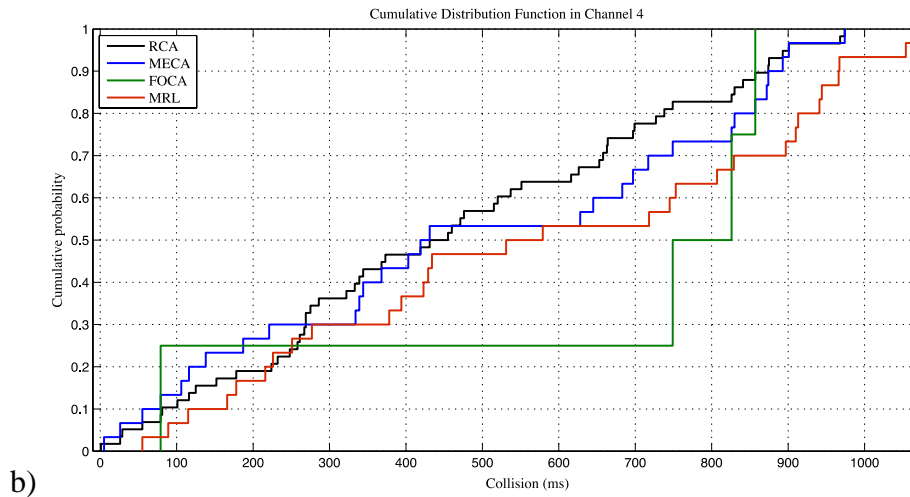

Figure 6. Channel collision probability in the considered primary channels



a)



b) Figure 7. Evaluation of cumulative distribution function in channels 3 and 4.

Figure 8 demonstrates the channel handoff rates for RCA, MECA, FOCA, and MRL schemes within a time period of 5.0×10^3 s. The numerical results depict that spectrum handoff peaks at 19% , 70%, 45% and 25% for MECA, RCA, FOCA, and MRL schemes respectively. This is clearly shown that MECA scheme is more efficient compared to the RCA, FOCA, and MRL schemes. This is particularly true when the time consumed for spectrum handoff is high, a considerable decrease in throughput for the SU occurs.

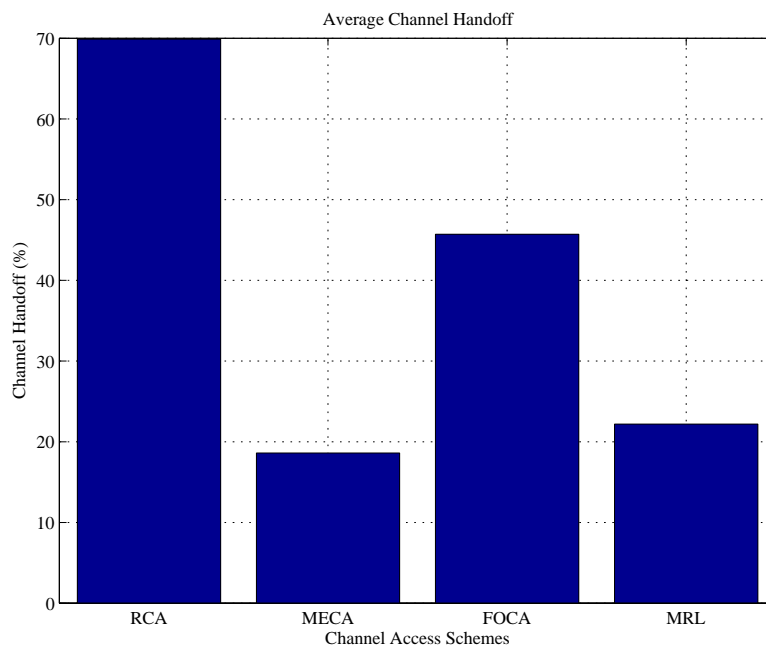

Figure 8. Channel handoff rate in proposed spectrum opportunity access schemes

VIII. CONCLUSION AND FUTURE WORKS

In this paper, we have considered a cognitive radio network located within a primary network with multi-licensed channels. On the basis of this model, we proposed a weighted residual entropy algorithm to improve secondary use of unoccupied frequency bands. The numerical performances are evaluated against RCA, FOCA, and MRL spectrum access schemes. According to the simulation results obtained, it can be seen that the proposed MECA scheme has great performance and can improve system efficiency in comparison with RCA, FOCA, and MRL schemes. Hence, the obtained outcomes demonstrated an improvement of average channel utilization, decreasing of channel collision and channel handoff rates. These achievements proved that the proposed spectrum decision is more energy efficient in an intermittent spectrum environment.

In realistic systems, there exist many issues, which require more investigation, such as diverse channel access strategies in multi-standard cognitive radio networks, intelligent and dynamic channel modeling, and channel collision awareness mechanisms might be considered during the process of the decision-making. Also cooperative spectrum decision in multi-user heterogeneous networks is an open research area, which needs more investigation.

ACKNOWLEDGEMENTS

The authors acknowledge contribution from their colleagues, in particular Olayinka Adigun for reading the manuscript and his comments.

APPENDIX

The weighted residual entropy at time t of a random lifetime X is the differential weighted entropy of $[X | X > t]$ which can be given by:

$$H^w(X;t) = - \int_t^{\infty} x \frac{f_X(x)}{F_X(t)} \log \frac{f_X(x)}{F_X(t)} dx \quad (18)$$

We note that period of idle channel is exponential random variable with relate probability density function

$$f_X(x) = me^{-mx} \quad (19)$$

Here $\bar{F}(t) = 1 - F_X(t)$

Which represents survival function of random variable.

And $\bar{F}_X(t) = e^{-mt}$

By substituting (19) into (18) the weighted residual entropy can be written as;

$$H^w(X;t) = - \int_0^{\infty} x m e^{-m(x-t)} \log m e^{-m(x-t)} dx = -(\log m - mt) \int_0^{\infty} \left(\frac{x}{m} + \frac{1}{m^2}\right) e^{-mx} dx + \int_0^{\infty} mx^2 e^{-mx} dx \quad (20)$$

By applying integration by parts, (19) can be recalled as;

$$H^w(X;t) = -(\log m - mt) \int_0^{\infty} \left(\frac{x}{m} + \frac{1}{m^2}\right) e^{-mx} dx - \int_0^{\infty} \left(x^2 + \frac{2x}{m} + \frac{2}{m^2}\right) e^{-mx} dx = t + \frac{2}{m} - (t + \frac{1}{m}) \log m \quad (21)$$

REFERENCES

- [1] "Estimated spectrum bandwidth requirements for the future development of IMT-2000 and IMT-Advanced," International Telecommunication Union, 2010.
- [2] "Spectrum policy task force report," Federal Communications Commission, 2002.
- [3] Zhao Q, M. Sadler B. A Survey of dynamic spectrum access: Signal processing, networking, and regulatory policy. *IEEE Signal Processing Magazine* 2007; 24: 79-89.
- [4] F. Akyildiz I, Lee W.Y, C. Vuran M, Mohant S. A Survey on Spectrum Management in Cognitive Radio Network. *IEEE Communications Magazine*, April 2008.
- [5] Mitola III J. Cognitive radio: An integrated agent architecture for software defined radio. KTH Royal Institute of Technology, 2000.
- [6] Haykin S. Cognitive Radio: Brain-empowered wireless communications. *IEEE Journal on Selected Area in communications* 2005; 23; 2 : 201-220.
- [7] Jo O., Cho D.H. Efficient spectrum matching based on spectrum characteristics in cognitive radio systems. *Wireless Telecommunication Symposium* 2008, pp. 230-235.
- [8] Wen Z, Fan C, Zhang X, Wu Y, Zou J, Liu J. A learning spectrum hole prediction model for cognitive radio systems. *10th IEEE International Conference on Computer and Information Technology*, Bradford, UK, 2010.
- [9] Ghosh C, Pagadarai S, P. Agrawal D, M. Wyglinski A. A framework for statistical wireless spectrum occupancy modelling. *IEEE transaction on Wireless Communications* 2010; 9, 1: 38-44.

- [10] Motamedi A, Bahai A. Optimal channel selection for spectrum-agile low-power wireless packet switched networks in unlicensed band. *EURASIP Journal on Wireless Communications and Networking* 2008.
- [11] Xiao Q, Li Y, Zhao M, Zhou S, Wang J. Opportunistic channel selection approach under collision probability constraint in cognitive radio systems *Computer Communication* 2009 ; 32: 1914-1922.
- [12] Yuan G, C. Grammenos R, Yang Y, Wang W. Performance analysis of selective opportunistic spectrum access with traffic prediction. *IEEE Transactions on Vehicular Technology* 2010 ; 59, 4: 1949-1959.
- [13] Sharma M, Sahoo A, Nayak K.D. Alternating Renewal Theory-based MAC Protocol for Cognitive Radio Networks. Indian Institute of Technology Bombay, Mumbai, 2008.
- [14] Yoon S.U, Ekici E. Voluntary spectrum handoff: a novel approach to spectrum management in CRNs. *IEEE International Conference on Communications ICC* 2010.
- [15] M. Ross S. *Stochastic Process*, 2nd ed. Wiley: New York, 1996.
- [16] Li X, Zekavat S. A. Traffic Pattern Prediction and Performance Investigation for Cognitive Radio Systems . *WCNC* 2008, pp. 894-899.
- [17] Pirmoradian M, Politis C. Optimal Spectrum Hole Selection & Exploitation in Cognitive Radio Networks. *International Telecommunication Union- Kladoscopic (ITU-K2011)*, Cape Town 2011.
- [18] Pirmoradian M, Politis C. Intelligent Channel Access Technique in Cognitive Radio Networks. *10th IEEE Conference on Cybernetic and Intelligent Systems (CIS2011)*, London, 2011.
- [19] Ebrahimi N. How to measure uncertainty in the life time distributions. *Sankhya* 1996; 58: 48-57.
- [20] Di Crescenzo A, Longobardi M. On weighted residual and past entropies. *Scientiae Math.* 2006; 64: 255-266.
- [21] Longo G. A noiseless coding theorem for sources having utilities. *Journal on Applied Mathematics* 1976; 30: 4: 739-748.
- [22] Trivedi K. S. *Probability and Statistics with Reliability, Queuing, and Computer Science Applications*, 2nd ed. Wiley : New York, 2002.

Table 1: Network notations

Symbol	Notation
$N(t)$	Set of the vacant channels at time t
$W_j(t)$	Selection status of the idle channel j at time t
X_j	Spectrum hole on channel j
m_{off}^i	Parameter of Exponential distribution for idle state on channel i
m_{on}^i	Parameter of Exponential distribution for busy period on channel i
$f_X(x)$	Probability density function of the random variable X (idle channel)
$E(\cdot)$	Average value function
$F(x)$	Cumulative distribution function of the random variable X
$H(X;t)$	Residual entropy function of random variable X
$H^w(X;t)$	Weighted residual entropy function of random variable X
$SH_j(t)$	Selected spectrum hole on channel i at time t
$\bar{F}(x)$	Survival function of the random variable X (idle channel)