

On Stability of Stiffened Cylindrical Shells with Varying Material Properties

M. Karami Khorramabadi and P. Khazaeinejad

Abstract—The static stability analysis of stiffened functionally graded cylindrical shells by isotropic rings and stringers subjected to axial compression is presented in this paper. The Young's modulus of the shell is taken to be function of the thickness coordinate. The fundamental relations, the equilibrium and stability equations are derived using the Sander's assumption. Resulting equations are employed to obtain the closed-form solution for the critical axial loads. The effects of material properties, geometric size and different material coefficient on the critical axial loads are examined. The analytical results are compared and validated using the finite element model.

Keywords—Functionally graded material, Stability, Stiffened cylindrical shell, Finite element analysis

I. INTRODUCTION

STIFFENED cylindrical shells have found widespread use in modern engineering, especially in aircraft and spacecraft industry. There have been many studies on the stability of cylindrical shells but closed-form solutions are possible only for the case which all edges are simply supported. Due to the increasing demands of high structural performance requirements, the study of functionally graded materials in structures has received considerable attention in recent years.

The buckling and postbuckling of cylindrical shells under combined loading of external pressure and axial compression are demonstrated by Shen and Chen [1]. The instability analysis of stiffened cylindrical shells under hydrostatic pressure is given by Barush and Singer [2]. The postbuckling of stiffened cylindrical shells under combined external pressure and axial compression is investigated by Shen et al. [3]. Using a novel finite elements model, Sridharan and Zeggane [4] studied the interaction of local and overall buckling in stiffened plates and cylindrical shells. Numerical examples of plate and shell structures are presented to throw light on these aspects of the methodology as well as to demonstrate the accuracy and efficiency of the model. Zeng and Wu [5] reported the postbuckling analysis of stiffened braided thin shells subjected to combined loading of external

pressure and axial compression. Yaffe and Abramovich [6] have analyzed numerically and experimentally the dynamic buckling of cylindrical stringer-stiffened shells. Spagnoli [7] studied the different modes of instability in stiffened conical shells under axial compression through a linear eigenvalue finite element analysis. Kidane et al. [8] derived the buckling loads of a generally cross and horizontal grid stiffened composite cylinder by developing an analytical model for determination of the equivalent stiffness parameters of a grid stiffened composite cylindrical shell. Rikards et al. [9] employed a triangular finite element model to study the buckling and vibration of laminated composite stiffened shells and plates based on the first order shear deformation theory. The stabilization of a functionally graded (FG) cylindrical shell under axial harmonic loading is investigated by Ng et al. [10]. Narimani et al. [11] was developed a closed-form solution based on the first order shear deformation theory to study the buckling loads of FG cylindrical shells under three types of mechanical loadings.

The main purpose of the present paper is to investigate the buckling behavior of FG stiffened cylindrical shells by isotropic rings and stringers under axial compression. The Donnell nonlinear strain-displacement relations are employed to derive the equilibrium and stability equations. The closed-form solution is used to obtain the critical axial loads. The numerical results of the critical loads are presented for variation of the material properties and geometric size of the shell. To validate the analytical solution, a finite element analysis is employed.

II. THEORETICAL DEVELOPMENT

Fig. 1 illustrates the geometry and configuration of a cylindrical shell of mean radius a , thickness h , and length L with the cylindrical coordinates (x, θ, z) made of functionally graded materials. A power law distribution is chosen to describe the variation of the Young's modulus in the thickness direction as [11]

$$E(z) = E_m + E_{cm} \left(\frac{2z+h}{2h} \right)^k \quad (1)$$
$$E_{cm} = E_c - E_m$$

M. Karami Khorramabadi is with the Department of Mechanical Engineering, Islamic Azad University, Khorramabad Branch, Khorramabad, Iran (corresponding author to provide phone: +98 661 2204463; fax: +98 661 2214281; e-mail: mehdi_karami2001@yahoo.com).

P. Khazaeinejad, is with the Department of Mechanical Engineering, Islamic Azad University, Arak Branch, Arak 38135-567, Iran (e-mail: khazaeinejad@asme.org).

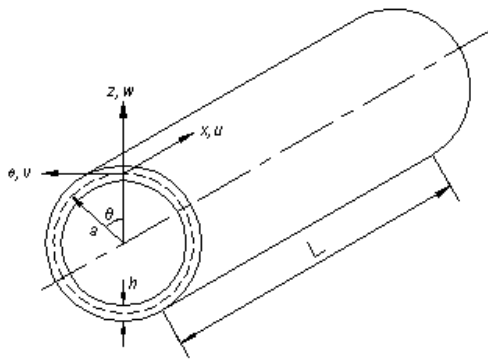

Fig.1 Geometry of FG circular cylindrical shell.

where k is the material coefficient and subscripts m and c refer to the metal and ceramic constituents, respectively. The Donnell form of the kinematic relations for cylindrical shells is as follows [12]

$$\begin{aligned} \varepsilon_x &= u_{,x} + \frac{1}{2}w_{,x}^2, \\ \varepsilon_\theta &= \frac{v_{,\theta} + w}{a} + \frac{w_{,\theta}^2}{2a^2}, \\ \gamma_{x\theta} &= \left(\frac{u_{,\theta}}{a} + v_{,x} \right) + \frac{w_{,x}w_{,\theta}}{a} \\ k_x &= -w_{,xx}, \quad k_\theta = -\frac{w_{,\theta\theta}}{a^2}, \quad k_{x\theta} = -\frac{w_{,x\theta}}{a} \end{aligned} \quad (2)$$

where u, v and w are the axial, circumferential, and lateral displacements of shell, respectively, $\varepsilon_x, \varepsilon_\theta$ and $\gamma_{x\theta}$ are the normal and shear strains, respectively and k_x, k_θ and $k_{x\theta}$ are the curvatures. Also, the indices x and θ refer to the axial and circumferential directions, respectively. A thin-walled FG cylindrical shell, stiffened by closely spaced circular rings attached to the inside of the shell skin and with longitudinal stringers attached to the outside is considered (see Fig. 2). For a shell-wall construction that is not symmetrical relative to the shell middle surface, there is a coupling between extensional forces and curvature change and between bending moments and extensional strains. To account for this coupling effect the constitutive equations are expressed as [12]

$$\begin{aligned} N_x &= C_{11}\varepsilon_x + C_{12}\varepsilon_\theta + C_{14}k_x + C_{15}k_\theta \\ N_\theta &= C_{12}\varepsilon_x + C_{22}\varepsilon_\theta + C_{24}k_x + C_{25}k_\theta \\ N_{x\theta} &= C_{33}\gamma_{x\theta} + C_{36}k_{x\theta} \\ M_x &= C_{14}\varepsilon_x + C_{24}\varepsilon_\theta + C_{44}k_x + C_{45}k_\theta \\ M_\theta &= C_{15}\varepsilon_x + C_{25}\varepsilon_\theta + C_{45}k_x + C_{55}k_\theta \\ M_{x\theta} &= C_{36}\gamma_{x\theta} + C_{66}k_{x\theta} \end{aligned} \quad (3)$$

where the stiffness parameters C_{ij} are given by

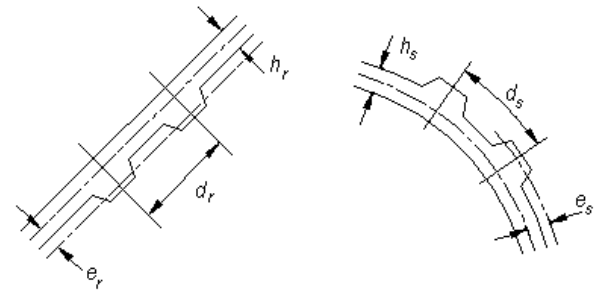

Fig. 2 Schematic view of shell-wall construction for FG stiffened cylindrical shell.

$$\begin{aligned} C_{11} &= \frac{E_1}{1-\nu^2} + \frac{E_{1s}b_s}{d_s}, & C_{12} &= \frac{\nu E_1}{1-\nu^2}, \\ C_{14} &= \frac{E_2}{1-\nu^2} + \frac{E_{2s}b_s}{d_s}, & C_{15} &= \frac{\nu E_2}{1-\nu^2}, \\ C_{22} &= \frac{E_1}{1-\nu^2} + \frac{E_{1r}b_r}{d_r}, & C_{24} &= \frac{\nu E_2}{1-\nu^2}, \\ C_{25} &= \frac{E_2}{1-\nu^2} + \frac{E_{2r}b_r}{d_r}, & C_{33} &= \frac{E_1}{2(1+\nu)} \\ C_{36} &= \frac{E_2}{1+\nu}, & C_{44} &= \left(\frac{E_3}{1-\nu^2} + \frac{E_{3s}b_s}{d_s} \right), \\ C_{45} &= \frac{\nu E_3}{1-\nu^2}, & C_{55} &= \frac{E_3}{1-\nu^2} + \frac{E_{3r}b_r}{d_r} \\ C_{66} &= \frac{E_3}{1+\nu} + \frac{1}{2} \left(\frac{G_s J_s}{d_s} + \frac{G_r J_r}{d_r} \right) \\ C_{63} &= \frac{E_2}{2(1+\nu)}, \end{aligned} \quad (4)$$

where

$$\begin{aligned} E_1 &= E_m h + \frac{E_{cm} h}{k+1} \\ E_2 &= \frac{k E_{cm} h^2}{2(k+1)(k+2)} \\ E_3 &= \frac{E_m h^3}{12} + E_{cm} h^3 \left(\frac{1}{4(k+1)} - \frac{1}{k+2} + \frac{1}{k+3} \right) \\ E_{1s} &= \int_{-\frac{h_s}{2}}^{\frac{h_s}{2}} E(z) dz, \quad E_{1r} = \int_{-\frac{h_r}{2}}^{\frac{h_r}{2}} E(z) dz, \\ (E_{2s}, E_{3s}) &= \int_{e_s - \frac{h_s}{2}}^{e_s + \frac{h_s}{2}} E(z) (z, z^2) dz \\ (E_{2r}, E_{3r}) &= \int_{e_r - \frac{h_r}{2}}^{e_r + \frac{h_r}{2}} E(z) (z, z^2) dz \end{aligned} \quad (5)$$

where subscripts s and r refer to the stringers and rings, respectively. Note that, the thickness and width for stringers are respectively denoted by h_s and b_s and for rings are h_r and b_r . Also, d_s and d_r are the distances between two stringers and rings, respectively and the eccentricities e_s and e_r represent the distance from the shell middle surface to the centroid of the stiffener cross section (Fig. 2). In Eq. (3), the stress resultants N_i and M_i are expressed as

$$(N_i, M_i) = \int_{-\frac{h}{2}}^{\frac{h}{2}} \sigma_i(1, z) dz \quad i = x, \theta, x\theta \quad (6)$$

Using the minimum potential energy criterion [12], the equilibrium equations of stiffened cylindrical shells are established as follow

$$\begin{aligned} aN_{x,x} + N_{x\theta,\theta} &= 0 \\ aN_{x\theta,x} + N_{\theta,\theta} &= 0 \\ aM_{x,xx} + 2M_{x\theta,x\theta} + \frac{1}{a}M_{\theta,\theta\theta} - N_{\theta} \\ &+ aN_x w_{,xx} + 2N_{x\theta} w_{,x\theta} + \frac{1}{a}N_{\theta} w_{,\theta\theta} = -Pa \end{aligned} \quad (7)$$

The stability equations of cylindrical shell may be derived by the variational approach. If V is the total potential energy of the shell, the first variation δV is associated with the state of equilibrium. The stability of the original configuration of the shell in the neighborhood of the equilibrium state can be determined by the sign of second variation $\delta^2 V$. However, the condition of $\delta^2 V = 0$ is used to derive the stability equations of many practical problems on the buckling of shells [12]. Thus, the stability equations are represented by the Euler equations for the integrand in the second variation expression

$$\begin{aligned} aN_{x1,x} + N_{x\theta1,\theta} &= 0 \\ aN_{x\theta1,x} + N_{\theta1,\theta} &= 0 \\ aM_{x1,xx} + 2M_{x\theta1,x\theta} + \frac{1}{a}M_{\theta1,\theta\theta} - N_{\theta1} \\ &+ aN_{x0} w_{1,xx} + 2N_{x\theta0} w_{1,x\theta} + \frac{1}{a}N_{\theta0} w_{1,\theta\theta} = 0 \end{aligned} \quad (8)$$

The terms with the subscript 0 are related to the state of equilibrium and terms with the subscript 1 are those characterizing the state of stability. By substituting Eq. (3) into (8), the stability equations can be derived in terms of displacement components.

III. BUCKLING ANALYSIS

To determine the critical axial loads, the prebuckling mechanical forces should be found from the equilibrium equations and then substituted into the stability equations for the buckling analysis. Under a uniformly distributed axial compressive load P , the cylinder shortens, except at the ends, and increases in diameter. The initial deformation is axisymmetric and the prebuckling mechanical forces are given by [12]

$$N_{\theta 0} = N_{x\theta 0} = 0, \quad N_{x0} = -\frac{P}{2\pi a} \quad (9)$$

Upon substituting the prebuckling forces into the stability equations (8) in terms of displacement components, a set of three differential equations is obtained. To solve this set of equations, the following approximate solutions, which satisfy the resulting equations and the simply supported boundary conditions are assumed

$$\begin{aligned} u_1 &= \sum_{m=1}^{\infty} \sum_{n=1}^{\infty} U_{mn} \cos \bar{m}x \sin n\theta \\ v_1 &= \sum_{m=1}^{\infty} \sum_{n=1}^{\infty} V_{mn} \sin \bar{m}x \cos n\theta \\ w_1 &= \sum_{m=1}^{\infty} \sum_{n=1}^{\infty} W_{mn} \sin \bar{m}x \sin n\theta \end{aligned} \quad (10)$$

where $\bar{m} = m\pi / L$. Substituting relations (10) into the stability equations in terms of displacement components gives

$$\begin{aligned} a_{11}A + a_{12}B + a_{13}C &= 0 \\ a_{12}A + a_{22}B + a_{23}C &= 0 \\ a_{13}A + a_{23}B + (a_{33} - \bar{P})C &= 0 \end{aligned} \quad (11)$$

where

$$\begin{aligned} a_{11} &= C_{11}\bar{m}^2 + C_{33}n^2, \quad a_{12} = (C_{12} + C_{33})\bar{m}n \\ a_{13} &= -\left(C_{12}\bar{m} + \frac{C_{14}}{a}\bar{m}^3 + \frac{1}{a}(C_{15} + C_{36})\bar{m}n^2 \right) \\ a_{22} &= C_{33}\bar{m}^2 + C_{22}n^2, \quad \bar{P} = P\bar{m}^2 / 2\pi a \\ a_{23} &= -C_{22}n - C_{25}\frac{n^3}{a} - \frac{1}{a}(C_{36} + C_{24})\bar{m}^2n \\ a_{33} &= C_{44}\frac{\bar{m}^4}{a^2} + \frac{2}{a^2}(C_{45} + C_{66})\bar{m}^2n^2 + \frac{n^4}{a^2}C_{55} \\ &+ C_{22} + \frac{2n^2}{a}C_{25} + \frac{2}{a}\bar{m}^2C_{24} \end{aligned} \quad (12)$$

which $[a]$ is a symmetric matrix. By setting $|a_{ij}|=0$ to obtain

the nonzero solution, the value of P is found

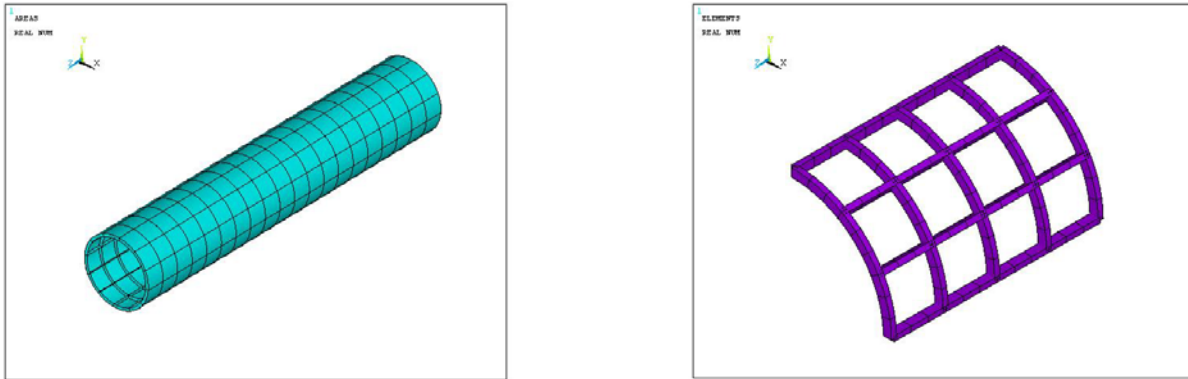

Fig. 3 FEM model for FG stiffened cylindrical shell with isotropic rings and stringers.

$$\frac{P}{2\pi a} = \frac{a_{33}}{\bar{m}^2} + \frac{2a_{12}a_{23}a_{13} - a_{22}a_{13}^2 - a_{11}a_{23}^2}{(a_{11}a_{22} - a_{12}^2)\bar{m}^2} \quad (13)$$

The critical axial load can be obtained by minimizing P with respect to m and n , the number of longitudinal and circumferential buckling waves. By setting the material coefficient to zero ($k = 0$) and minimizing with respect to m and n , Eq. (13) is reduced to the critical axial load of unstiffened homogeneous cylindrical shell

$$\frac{P}{2\pi a} = \frac{a_{33}}{\bar{m}^2} + \frac{2a_{12}a_{23}a_{13} - a_{22}a_{13}^2 - a_{11}a_{23}^2}{(a_{11}a_{22} - a_{12}^2)\bar{m}^2} \quad (14)$$

The above equation has been reported by Brush and Almorh [12].

The present analytical solution needs to be verified with some other mathematical computational model such as the FEM. For verification, we have used a finite element program code. The FEM analysis was done on a FG unstiffened and stiffened cylindrical shell using a 2-D FEM model (Fig. 3).

IV. NUMERICAL RESULTS

This paper presents the mechanical buckling analysis of functionally graded stiffened cylindrical shells by isotropic rings and stringers under axial compression load. A ceramic-metal FG cylindrical shell is considered. The FG cylindrical shell constituents are zirconia and aluminum. The inner surface of the FG cylindrical shell is composed of zirconia and the outer surface is composed of aluminum. The rings and stringers are isotropic and are made of aluminum. The Young's modulus for zirconia and aluminum are 151 GPa and 70 GPa, respectively. The Poisson's ratio is assumed to be constant and equal to 0.3. As a numerical example, we consider a FG stiffened cylindrical shell with 15 rings and stringers illustrated in Fig. 3. The following stiffened shell dimensions have been used:

$$\begin{aligned} a &= 0.24 \text{ m} \\ l &= 8.58 \text{ m} \\ h &= 7.19 \times 10^{-4} \text{ m} \\ h_s &= h_r = 7.62 \times 10^{-3} \text{ m} \\ b_s &= b_r = 2.46 \times 10^{-3} \text{ m} \\ d_s &= d_r = 2.54 \times 10^{-2} \text{ m} \end{aligned}$$

For the given values of the material coefficient k and thickness of shell, the values of m and n may be chosen by trial to give the smallest value of buckling load P . These values can be obtain by a suitable software or optimization program.

Comparisons of the critical axial loads for isotropic stiffened cylindrical shell are presented in Table 1. In this table for the case of isotropic cylindrical shell, it is assumed that $k = 0$. Table 1 shows that the buckling pressure increases by the increasing of the various R/L ratios. Comparisons of the critical axial loads for the functionally graded stiffened cylindrical shell with isotropic rings and stringers are presented in Tables 2. Table 2 shows that the buckling pressure by the increasing of the various h/L ratios. Also FEM results of the critical axial loads for FG stiffened cylindrical shell are shown in Fig. 4.

TABLE I
 COMPARING THE CRITICAL AXIAL LOADS (MPa) OF SIMPLY SUPPORTED
 HOMOGENEOUS CYLINDRICAL SHELLS ($k=0$).

R/L	Analytical	FEM
0.1	28.36	28.84
0.125	53.90	57.03
0.15	81.07	84.26
0.175	97.90	99.04
0.2	117.2	119.87
0.225	137.8	138.99

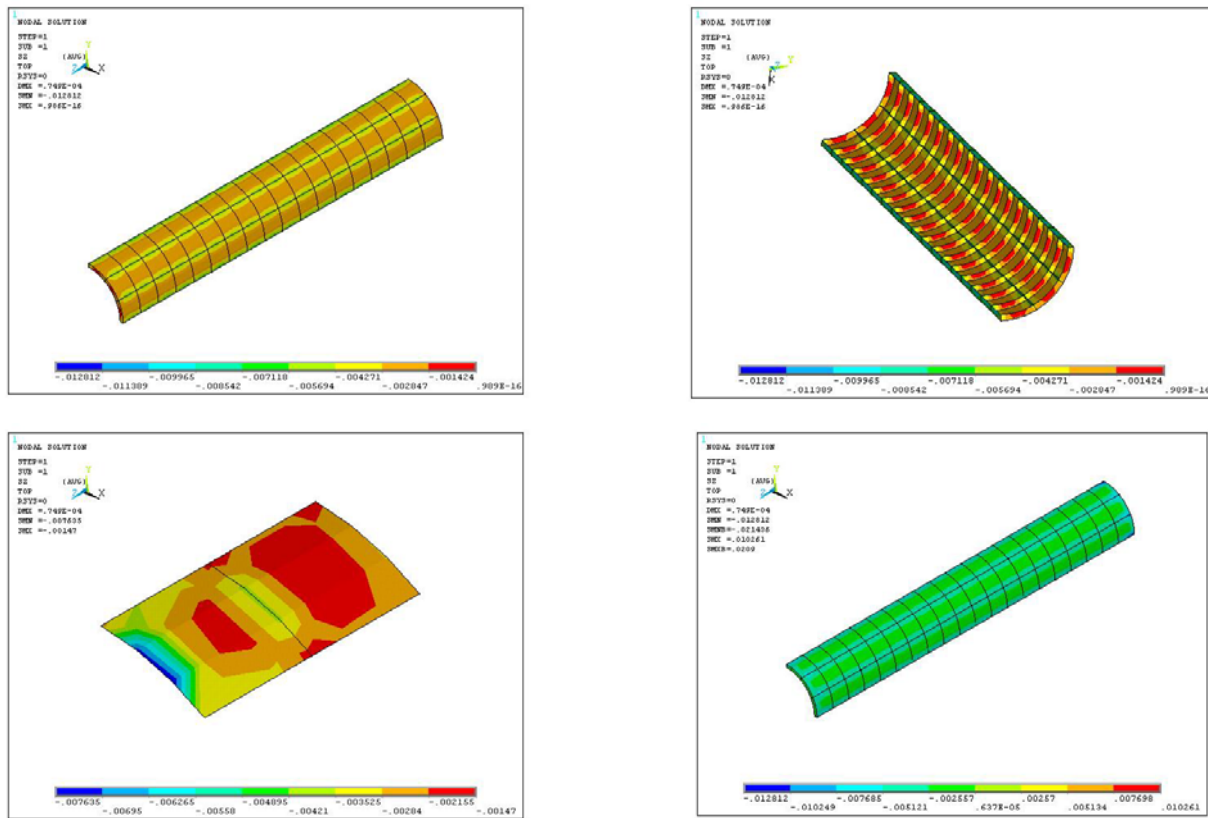

FIG. 4 FEM RESULTS FOR FG STIFFENED CYLINDRICAL SHELL WITH ISOTROPIC RINGS AND STRINGERS.

TABLE II
 COMPARING THE CRITICAL AXIAL LOADS (MPa) OF SIMPLY SUPPORTED
 FG CYLINDRICAL SHELL.

h/L	Analytical	FEM
0.0014	28.05	28.43
0.0016	36.78	38.87
0.0018	44.69	47.21
0.0020	51.47	54.36
0.0024	56.70	59.53
0.0026	60.00	63.18

V. CONCLUSION

In the present paper, equilibrium and stability equations of simply supported functionally graded stiffened cylindrical shells are obtained. Then, the buckling analysis of functionally graded stiffened cylindrical shells under uniformly axial compression load is investigated. It is conclude that:

1. The critical axial loads for homogeneous stiffened cylindrical shells are generally upper than the corresponding values for the homogeneous unstiffened cylindrical shells.
2. The critical axial loads for FG stiffened cylindrical shells are generally lower than the corresponding value for the homogeneous stiffened cylindrical shells.
3. The critical axial loads for FG stiffened cylindrical shells are generally upper than the corresponding value for the FG unstiffened cylindrical shells.

4. The critical axial loads are increased by increasing the shell thickness and decreasing the material coefficient.

REFERENCES

- [1] H.S. Shen, T.Y. Chen, Buckling and postbuckling behaviour of cylindrical shells under combined external pressure and axial compression, *Thin-Walled Struct.* 12 (1991) 321-334.
- [2] M. Barush, J. Singer, Effect of eccentricity of stiffeners on the general instability of stiffened cylindrical shells under hydrostatic pressure, *J. Mech. Eng. Sci.* 5 (1963) 23-27.
- [3] H.S. Shen, P. Zhou, T.Y. Chen, Postbuckling analysis of stiffened cylindrical shells under combined external pressure and axial compression, *Thin-Walled Struct.* 15 (1993) 43-63.
- [4] S. Sridharan, M. Zeggane, Stiffened plates and cylindrical shells under interactive buckling, *Finite Elem. Anal. Design*, 38 (2001) 155-178.
- [5] T. Zeng, L. Wu, Post-buckling analysis of stiffened braided cylindrical shells under combined external pressure and axial compression, *Compos. Struct.* 60 (2003) 455-466.
- [6] R. Yaffe, H. Abramovich, Dynamic buckling of cylindrical stringer stiffened shells, *Compu. Struct.* 81 (2003) 1031-1039.
- [7] A. Spagnoli, Different buckling modes in axially stiffened conical shells, *Eng. Struct.* 23 (2001) 957-965.
- [8] S. Kidane, G. Li, J. Helms, S. Pang, E. Woldeesenbet, Buckling load analysis of grid stiffened composite cylinders, *Compo. Part B: Eng.* 34 (2003) 1-9.
- [9] R. Rikards, A. Chate, O. Ozolinsh, Analysis of buckling and vibrations of composite stiffened shells and plates, *Comp. Struct.* 51 (2001) 361-370.
- [10] T.Y. Ng, Y.K. Lam, K.M. Liew, J.N. Reddy, Dynamic stability analysis of functionally graded cylindrical shells under periodic axial loading. *Int. J. Solids Struct.* 38 (2001) 1295-1300.

- [11] R. Narimani, M. Karami Khorramabadi, P. Khazaeinejad, Mechanical buckling of functionally graded cylindrical shells based on the first order shear deformation theory, ASME Pressure Vessels and Piping Division Conference, 2007, San Antonio, Texas, USA.
- [12] D.O. Brush, B.O. Almorh, Buckling of Bars, Plates and Shells, New York, McGraw-Hill, 1975.